

Dura Automotive Systems

Dura Modular EV Battery Tray

2021 Honorable Mention
Future of Lightweighting

- Modular and scalable design that can be tailored to multiple platforms and vehicle types for size, weight, and range
- Design can be implemented for A-Class, B-Class, C-Class, and D-Class vehicles plus pickup trucks and vans
- Weight saving ~10%, CO2 reduction of 3.8 metric tons during the life of program

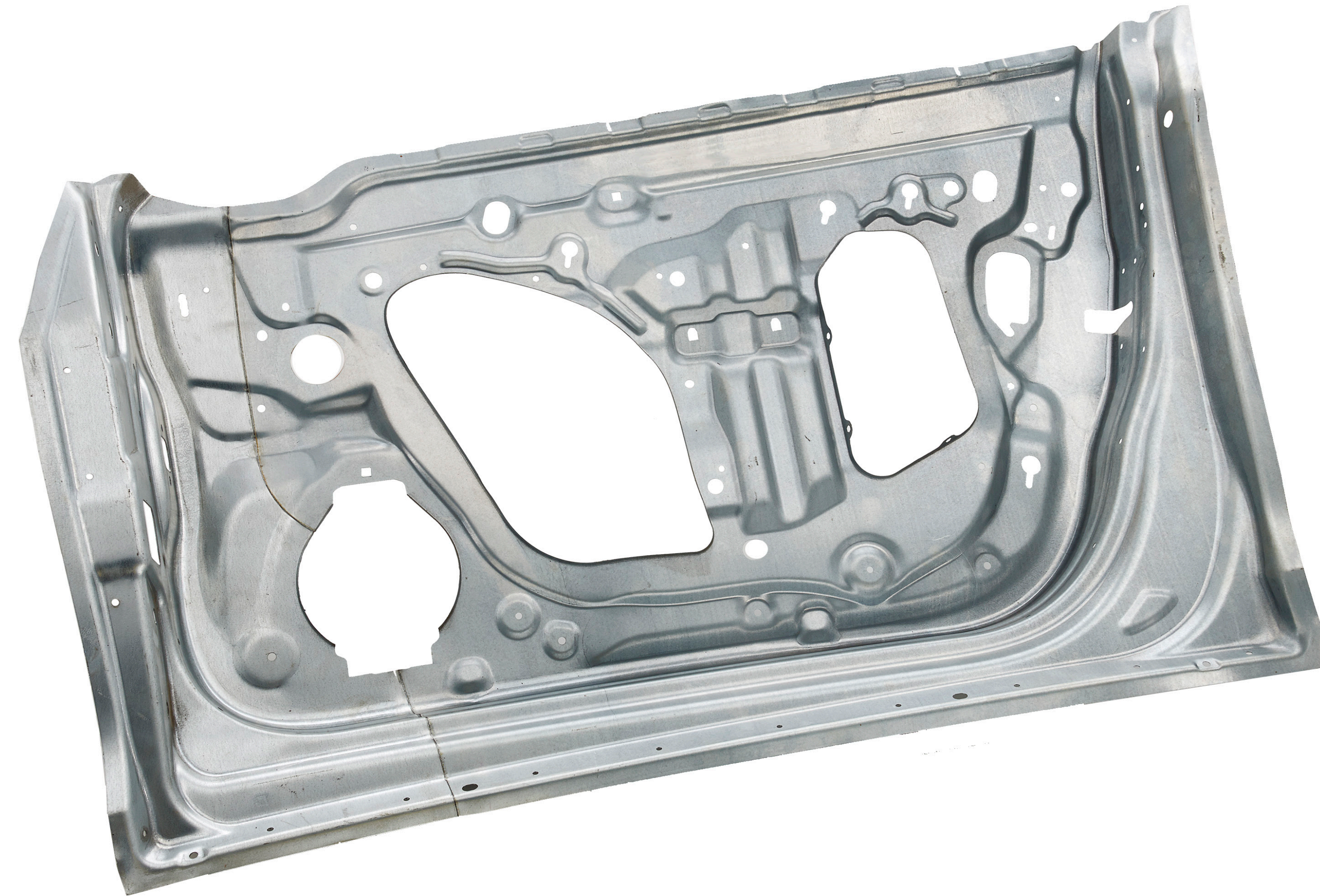

Shiloh Industries

Aluminum Curvilinear Laser Welded Blank

2021 Runner-up Future of Lightweighting

- First Aluminum curvilinear laser welded blank in the industry
- One Part, One Stamping - Eliminates original 4 parts
- Example Liftgate: 16% weight reduction, 5.3 Kg/vehicle (3M Kg Al saved/ year, 300K vehicles)
- Potential material & process saving: \$18/ vehicle (\$5.4 M/ year, 300K vehicles)

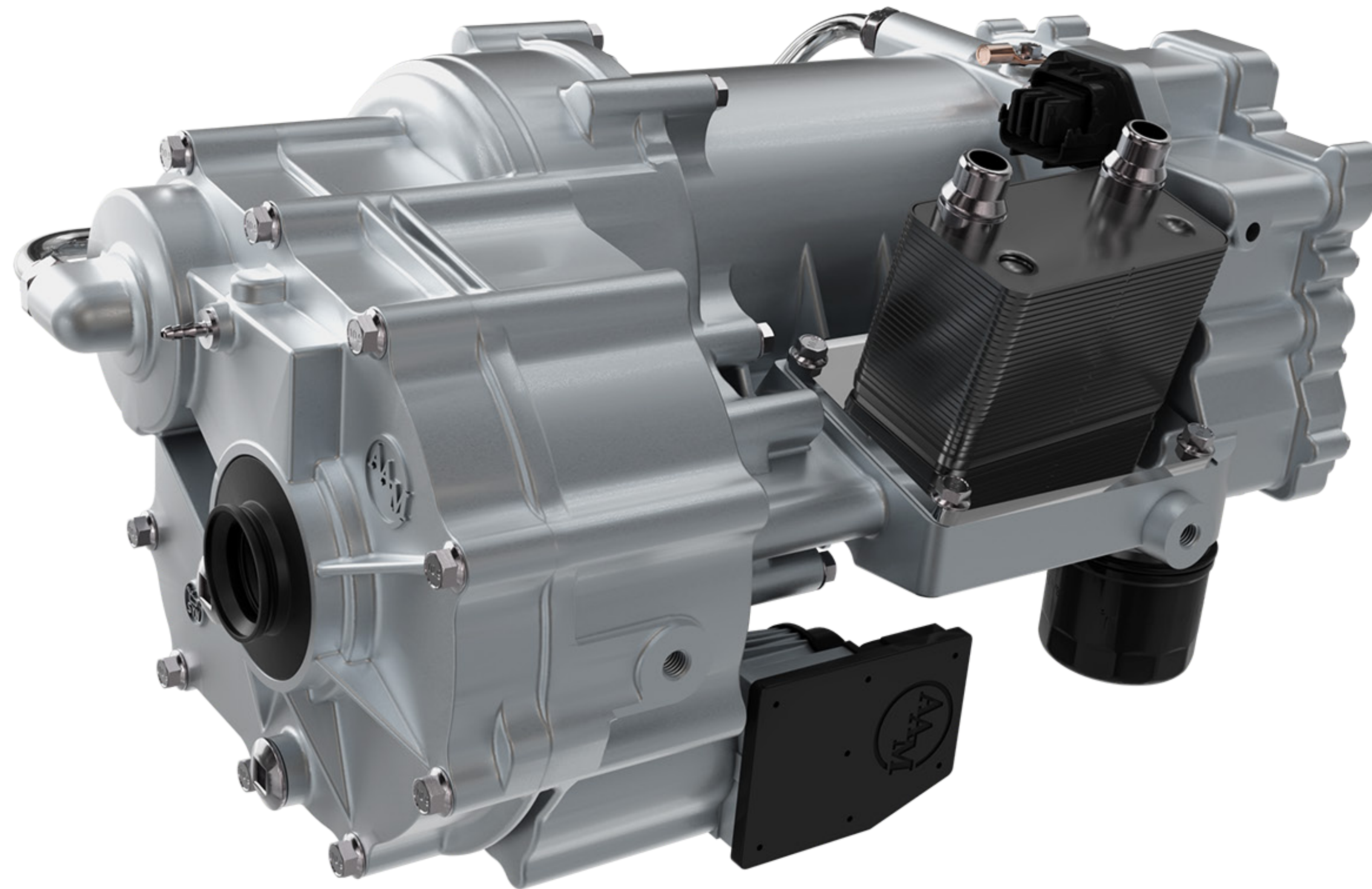

American Axle & Manufacturing

Electric Drive Unit (eDU)

2021 Winner
Future of Lightweighting

- Saves more than 25% mass over other units in the market
- Demonstrated higher power to weight ratio compared to competitors
- Integration of the electric machine, gearbox and inverter into a very compact and mass efficient package
- Utilizing a single oil cooling system that includes stator and shaft cooling, while requiring no seals



US Steel

Body-in-White Assembly
using U. S. Steel 980 XG3™
Gen3 AHSS

2021 Honorable Mention
Lightweighting
Enabling Technology

- Deliver strength of DP980 and formability of a DP590 without compromising weldability
- Significant weight savings, about 10% compared to an equivalent outgoing BIW
- Minimal manufacturing changes, broad supply base



JAC Group

JAC, SOL A5, Fastback Sports Car

2021 Runner-up
Lightweighting
Enabling Technology

- Established integrated simulation driven design process for body structural design
- Applied a multidisciplinary approach - weight, safety, NVH and durability
- Integrated design concept for sensitivity study and design optimization
- Achieved weight reduction of the whole vehicle: 106.3 Kgs

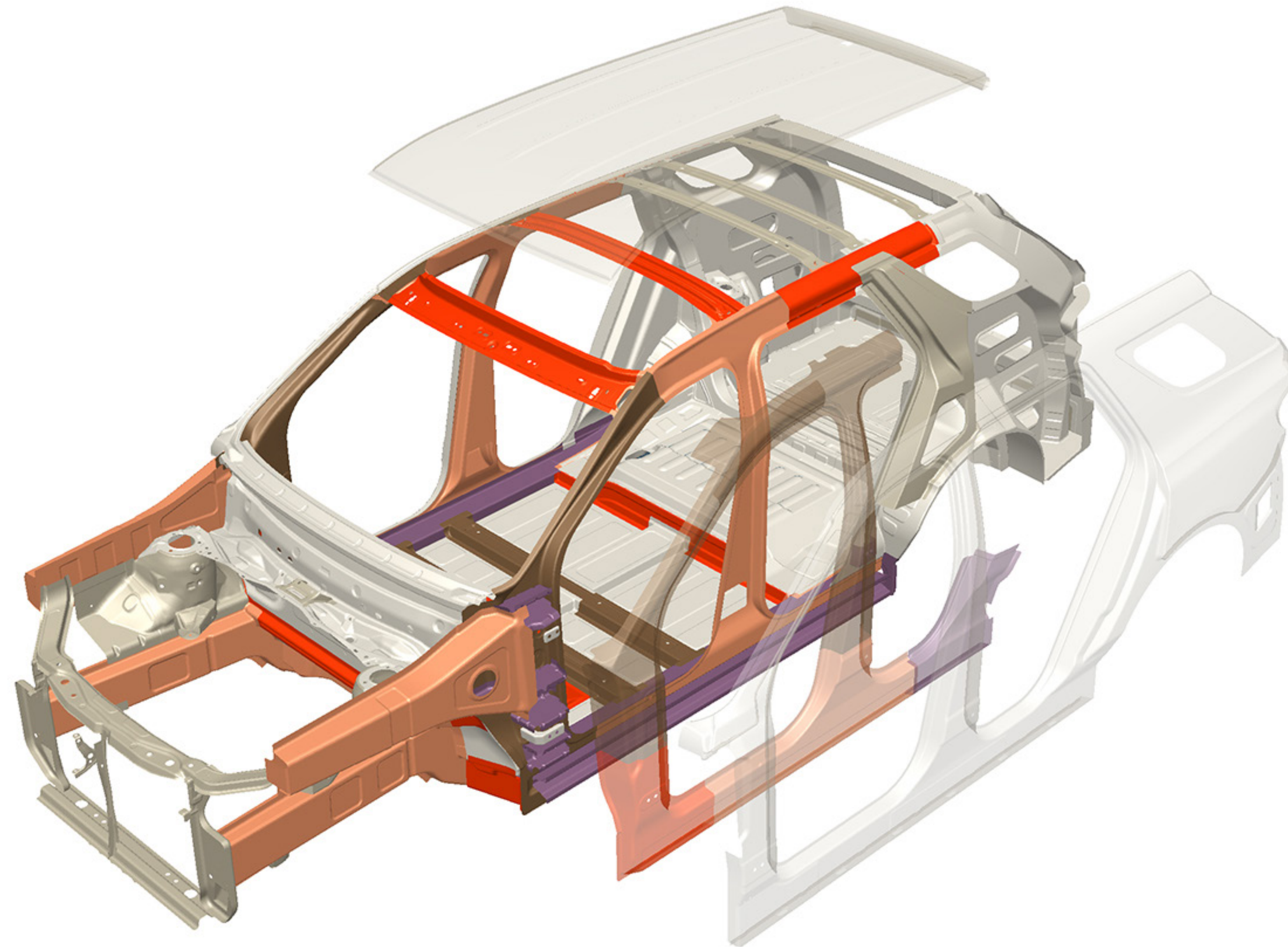

ArcelorMittal

GI Fortiform® 980, The 3rd Generation AHSS

2021 Winner Lightweighting Enabling Technology

- High ductility of DP600 for complex shapes at the higher strength level of 980 MPa
- Significant weight savings potential of up to 20%
- Resistance of Liquid Metal Embrittlement (LME)



Rassini Suspensiones

Lightweight Multi-Material Leaf Spring

2021 Runner-up
Module Lightweighting

- GFRP composite materials leads the concept of Multi-Material “Hybrid” Leaf Spring that achieves an approximate 30% component weight savings versus previous generation Leaf Spring
- Widely applicable to light duty trucks medium and heavy commercial vehicles (estimated 9M leaf springs per year used in the market)



Stellantis, BASF, L&L Products

2021 Jeep® Grand Cherokee Composite Tunnel Reinforcement

2021 Winner Module Lightweighting

- Industry 1st composite tunnel reinforcement designed to carry critical load path
- 40% weight savings on the component, and another 20% savings on the subsystem (4.6 lbs. total weight savings per vehicle)
- Lower overall cost (2.9% lower system level component cost. 18.5% lower Initial tooling cost)



Henkel, Nihon Parkerizing

PALLUMINA™ Metal Pretreatment Process

2021 Runner-up Sustainable Process

- Eliminates the use of heavy metal phosphates
- Reduces sludge generation up to 90%
- Decreases the use of water up to 50%
- Used in production of the 2021 Toyota Tacoma and Tundra

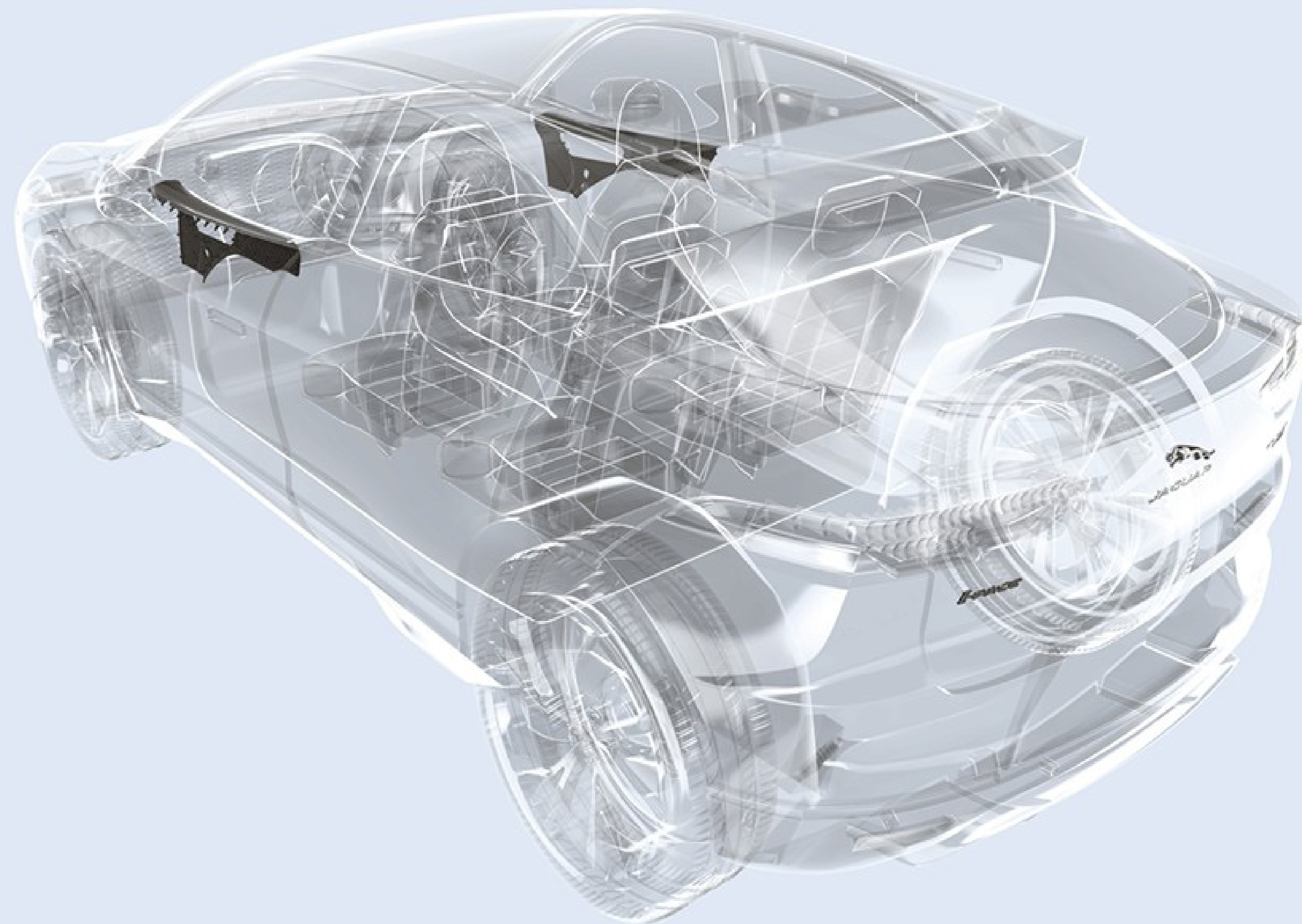

Faurecia

NAFILEan Stiff

2021 Winner Sustainable Process

- Polypropylene compound that uses 20% bio-sourced contents, 100% recyclable
- Latest innovation of the NAFILEan family, which is implemented in 17 production vehicles, standing to benefit a fleet of 14 million vehicles
- Delivering a 21% reduction in weight, saving of 100,000 tons in CO2 emissions, and an additional 811 million km travelled with the same quantity of fuel (assuming 10 year lifetime at 15,000 km/year for 14 million vehicles)



SAIC GM Wuling Automobile Co., Ltd.

Wuling Victory

2021 Runner-up Sustainable Product

- Reduced whole vehicle weight by 61.5 Kg (0.2 Liter of fuel consumption/ 100 Kms)
- Increased usage of high strength steel, ultra-high strength steel and hot forming process on Body-In-White to reach lightweighting and safety goals
- Each vehicle creates an enterprise's fuel consumption CAFC score benefit of about 500 yuan/ \$77.5 USD



Magna International

2019 RAM 1500 Active Air Deflector and Grille Shutter

2021 Winner
Sustainable Product - Component

- Improve aerodynamic drag by 9% for fuel economy
- Reduced CO2 emissions by 641.9 thousand metric tons since January of 2015
- Use light, cost effective and 78% recyclable plastics
- Widely applicable to other vehicles



Ford Motor Company

2021 Ford Mustang Mach-E

2021 Winner Sustainable Product - Vehicle

- Electrification - CO2-Zero, NGC Rating - 26 (Vehicle's environmental impact score, UK)
- Mach-E interior is 100% "vegan." No animal parts or skins used - Soyfoam headliner, Kenaf door bolsters, coffee chaff head and taillights, Miko synthetic suede
- Continuous evolution using sustainable materials and outstanding highway safety rating
- Car and Driver's 2021 EV of the Year