

ENLIGHTEN[®] AWARD 2020

PRESENTED BY ALTAIR

We congratulate our 2020 Altair Enlighten Award Winners



Harley-Davidson Motor Company Livewire, Electric Motorcycle

Full Vehicle Winner

- Electrification: Sustainability
- Energy capacity improved by 90%
- Ratio of energy capacity to mass improved by 60%
- Chassis stiffness increased 143% and 97% in the two primary directions of interest
- Rolling chassis mass reduced 2.3 kg

NUEVO NISSAN SENTRA TECNOLOGÍA PARA LO QUE SIGUE.



Nissan Sentra 2020 New Platform

Full Vehicle Runner-up

- Brand-new global platform
- Dramatic safety and performance improvement
- Increased UHSS application

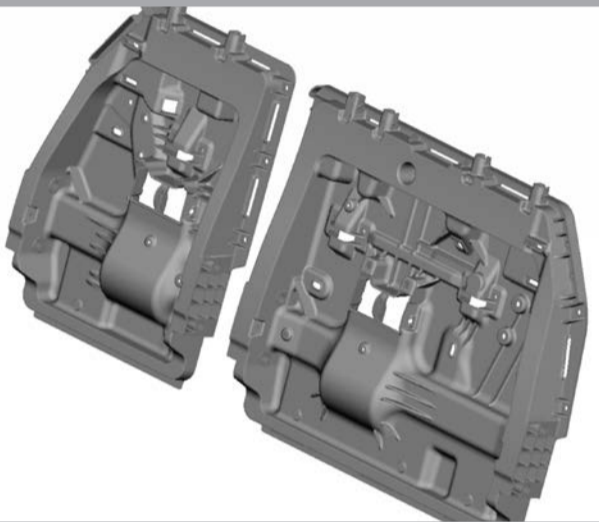

Toyota Injection Molded Fiber Reinforced Thermoplastic Seat Back

Module Winner

- 15% cost, and 30% mass reduction
- 2 x safety performance increase
- Consolidation of 15 components to one part
- Industry first free standing, two-occupant injection molded back frame



ZF Friedrichshafen AG Electric Park Brake

Module Runner-up

- First-to-market innovation with well over 150 million vehicles
- Over 25 lb weight reduction in heavy duty EPB
- Continuous improvement of redesigned actuator with minimum 25kN of clamping force per rear wheel



Marelli Advanced Sheet Compression Molded Suspension Steering Knuckle

Future of Lightweighting Winner

- 25% mass savings of newly developed ASMC suspension knuckle as compared to the aluminum version on a medium segment SUV
- 50% mass savings newly developed ASMC suspension knuckle as compared to the cast iron version of a medium segment SUV



Nissan Ultimate Lightweight Aluminum/CFRP Body Side Panel by Topology Design

Future of Lightweighting Runner-up

- Weight reduction of multi-material structure of aluminum and short fiber CFRTP
- Comparative weight reduction of about 50% in body side panel weight



Mubea (Muhr und Bender) Mubea GFRP Tension Leaf Spring

Enabling Technology Winner

- Innovation in GRP tension leaf springs
- Special geometry with bend at rear end of spring
- Comparative weight savings potential increased by up to 75%



DuPont Transportation & Industrial BETASEAL™ Bonded Thermoplastic Liftgates

Enabling Technology Runner-up

- Comparative weight savings of 20-30% for Magna thermoplastic liftgates bonded with BETASEAL™ X2500 structural adhesive
- Design of fast room temperature curing, two-component structural adhesive joining solution for mixed material construction

The Altair Enlighten Award, jointly presented with the Center for Automotive Research (CAR), is intended to honor the greatest achievements in vehicle weight savings each year. Learn more about nominees and winners of 2020 as well as how to take part in the Enlighten Award 2021 at: altairenlighten.com/award

Presented in cooperation with:



Supported by:



Mazda Knowledge Discovery using Multidisciplinary Design Optimization and Data Mining

Enabling Technology Honorable Mention

- Mazda provides a methodology that captures top technology trends applying simulation driven design and data analytics for product design. That provide inspiration to industry peers.