

Simulation-Driven Design: Solving the Geometry Problem

Abstract

Over the years, computer-aided design (CAD) system geometry has evolved: wireframes to surfaces to solids, and parametric to direct. Simulation, however, remains stuck using the same old beam, shell, or simplified-solids paradigm invented more than 50 years ago. As CAD geometric completeness has grown, so has the effort to convert it into a simpler form suitable for meshing and analysis. Traditional finite element analysis (FEA) vendors have focused on this task, but this has just increased the learning curve. The bottom line is that these “CAD to Mesh” steps require many judgment calls, are labor-intensive and error-prone, and require experts in both simulation and CAD. The result is that broad-based simulation today is limited to large companies with complex and expensive workflows and, even then, is rarely well integrated within the conceptual product design process. Our goal with Altair SimSolid™ is to change that. We are pioneering new methods that work directly on fully featured CAD assemblies and do not create a mesh. With this, you can work in step with your design process to analyze quickly and efficiently the original CAD geometry without modification or simplification. The result is that SimSolid is capable of analyzing large assemblies and complex parts that would not be considered practical with mainstream FEA. In this white paper, we will explain what SimSolid is and how it works and will show examples of where it can be used. In addition, we will discuss the technological foundations of SimSolid and compare it to methods used in traditional FEA.

The Geometry Problem

The geometry problem, simply put, is that the geometry of CAD and traditional FEA are different. CAD creates geometry to define design and manufacturing requirements. FEA needs to transform this into a simplified form to define the mesh. This disparity between CAD and FEA geometry models needlessly complicates the analysis user paradigm in many areas—some obvious, some subtle. The obvious complication is the need to dramatically simplify the geometry so that a mesh can be reliably created. Many decisions must be made as to which parts and part features can be removed without modifying the geometric design intent. This is an expertise-extensive process. Different people will likely create different results. The less-than-obvious complication involves the small tweaks to geometry often required to get the traditional FEA mesh generator to create adequate shaped elements or the special elements and special mesh transitions required to create connections between parts—bolts, welds, etc. The subtlest complication is the tolerance settings that might need to be made in the solution methods to account for numeric instabilities caused by poorly shaped meshes, especially in nonlinear analysis. The geometry problem is the primary inhibitor blocking wider adoption of simulation in design workflows. Incremental user interface improvement in geometry and meshing is not the solution. A fundamental process change is required.

The Altair SimSolid Solution

SimSolid takes a different approach. It solves the geometry problem by replacing altogether the underlying core FEA solution technology. Here are some important attributes of the SimSolid solution:

- The SimSolid methodology analyzes directly the fully featured CAD assembly. Time-consuming model simplification techniques, such as defeaturing and mid-surfacing, are not required.
- The solution methods used in SimSolid are meshless. There is never a user requirement to create a mesh.

- The SimSolid methodology is fast and efficient. It provides superior performance metrics for computational time and memory footprints that allow very large and/or complex assemblies to be solved quickly on desktop-class PCs.
- The SimSolid method is accurate. SimSolid controls solution accuracy using multipass adaptive analysis. Adaptivity can be defined on a global or part-local basis. And adaptivity is always active.

All of this is packaged as a lightweight (33 MB) Windows application, which provides both a direct connection to Onshape cloud documents and a convenient STL interface for the structural simulation of 3Dprinted parts.

The Benefits

SimSolid eliminates the two most time-consuming and expertise extensive tasks of geometry simplification and meshing. These two steps typically take between 30% and 70% of the total modeling and analysis time, so this represents significant process improvement. More important, these tasks represent the bulk of the training requirement for traditional FEA. Not only is less time required but also less training means that a larger pool of users can take advantage of the benefits that design simulation provides.

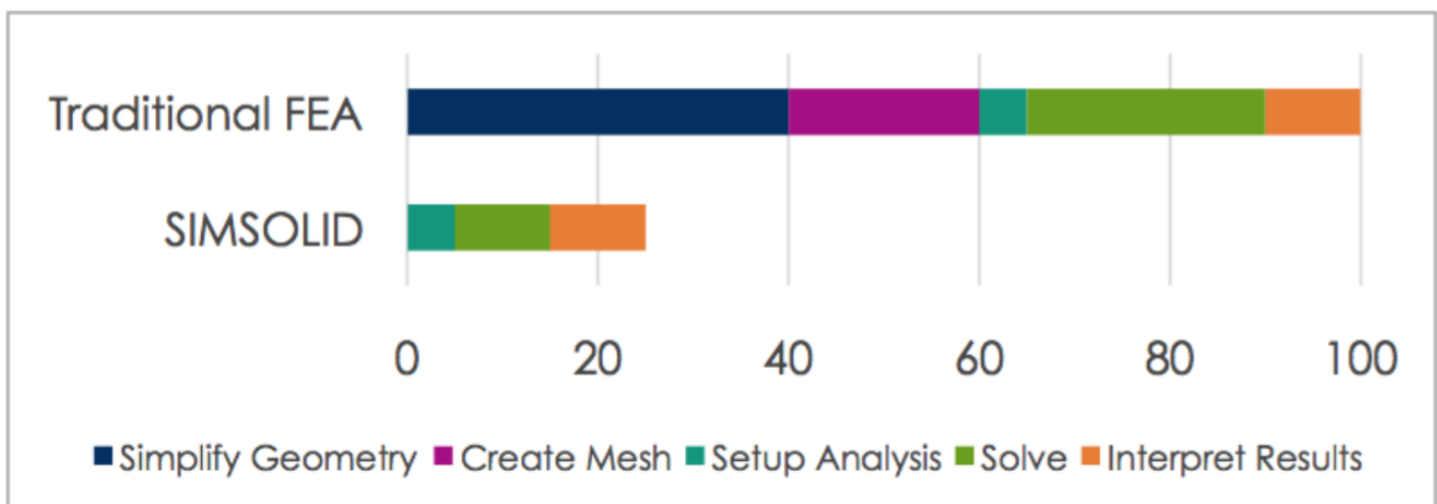

The second benefit is expanding the possibilities of what is practical to solve. Instead of reducing the assembly to one part or a small context of a few parts, a more complete assembly can be solved, simplifying the model setup and load and constraint specification. Many models that are not practical to use with traditional FEA can be solved using SimSolid.

Here are a few examples of the benefits of using SimSolid: Elimination of part-geometry simplification. With traditional FEA, the full-fidelity model must first be simplified by examining and then removing small features. Here is an example of the original CAD geometry and one possible simplification used in traditional FEA. Note that different analysts will likely simplify the geometry in different ways, further complicating verification of the analysis model.

Original CAD Model

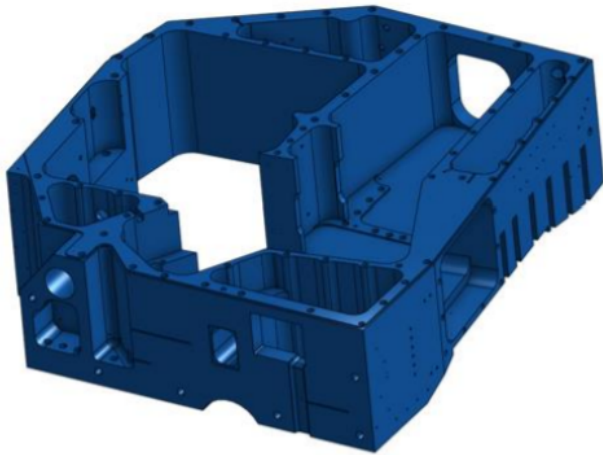

FEA Simplified Geometry

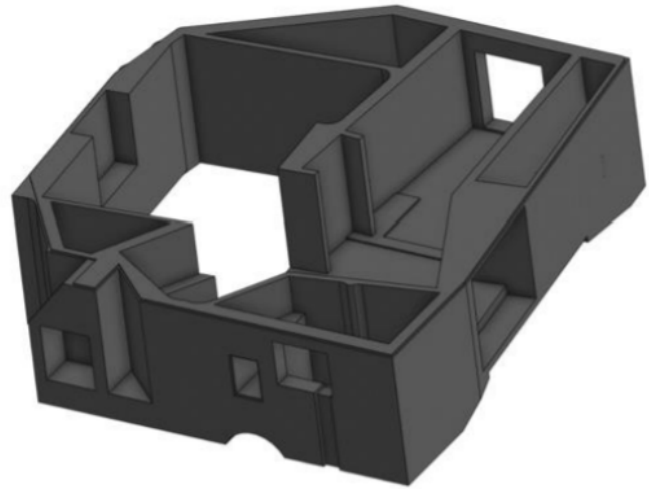

With SimSolid, all features are left in the model and the full fidelity geometry is used in the analysis. This geometry is a complex single part of 1,200+ faces and 150+ small holes. Solution time including model setup is less than four minutes, and reanalysis is fast—less than one minute.

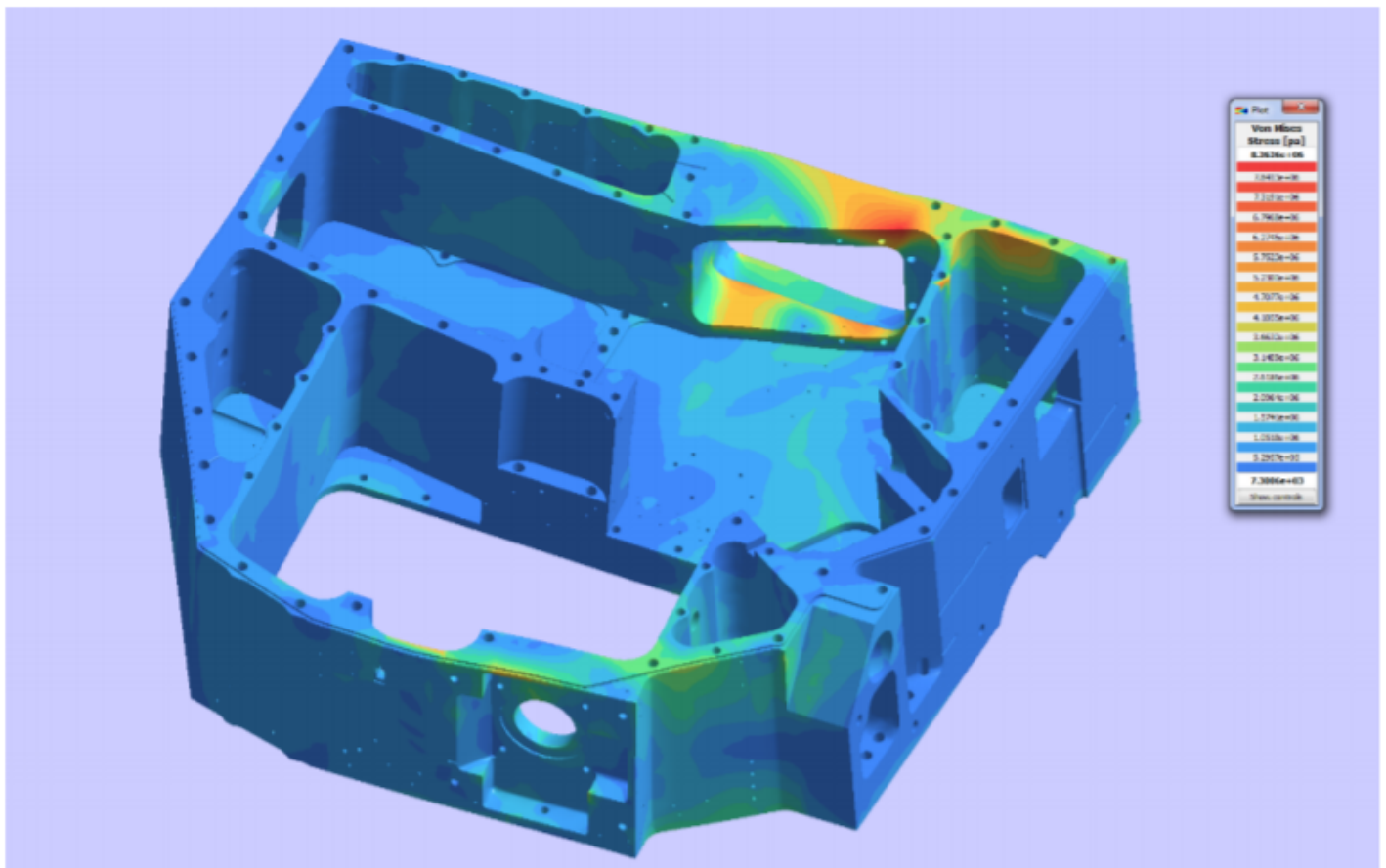

Elimination of part-geometry cleanup. Typical CAD geometry often has small or thin faces and odd face intersections. SimSolid is indifferent to these types of geometries. Here is a model with many small faces and even an imprint of letters on the surface. With traditional FEA, many surfaces would need to be edited, merged, or removed altogether.

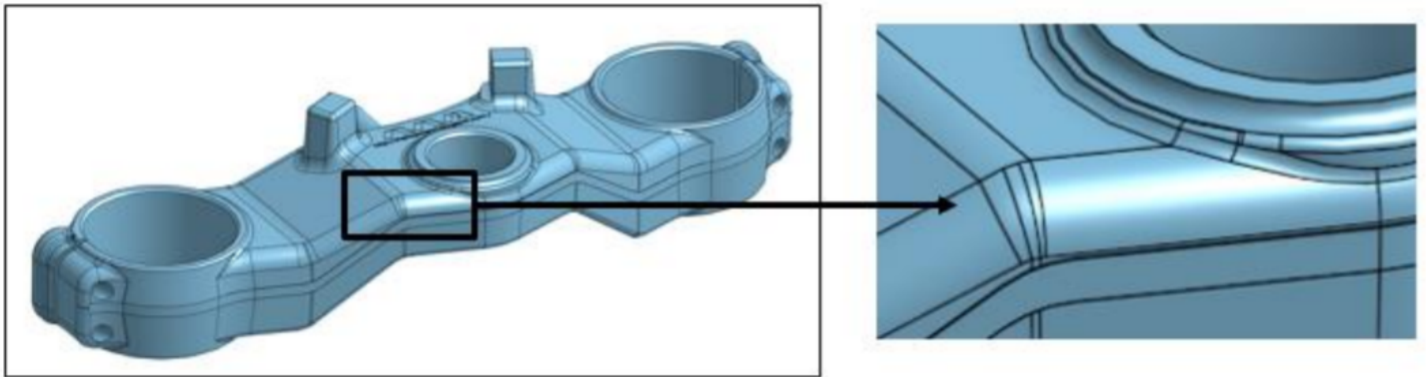

With SimSolid, this geometry can be analyzed directly, without any modification by the user.

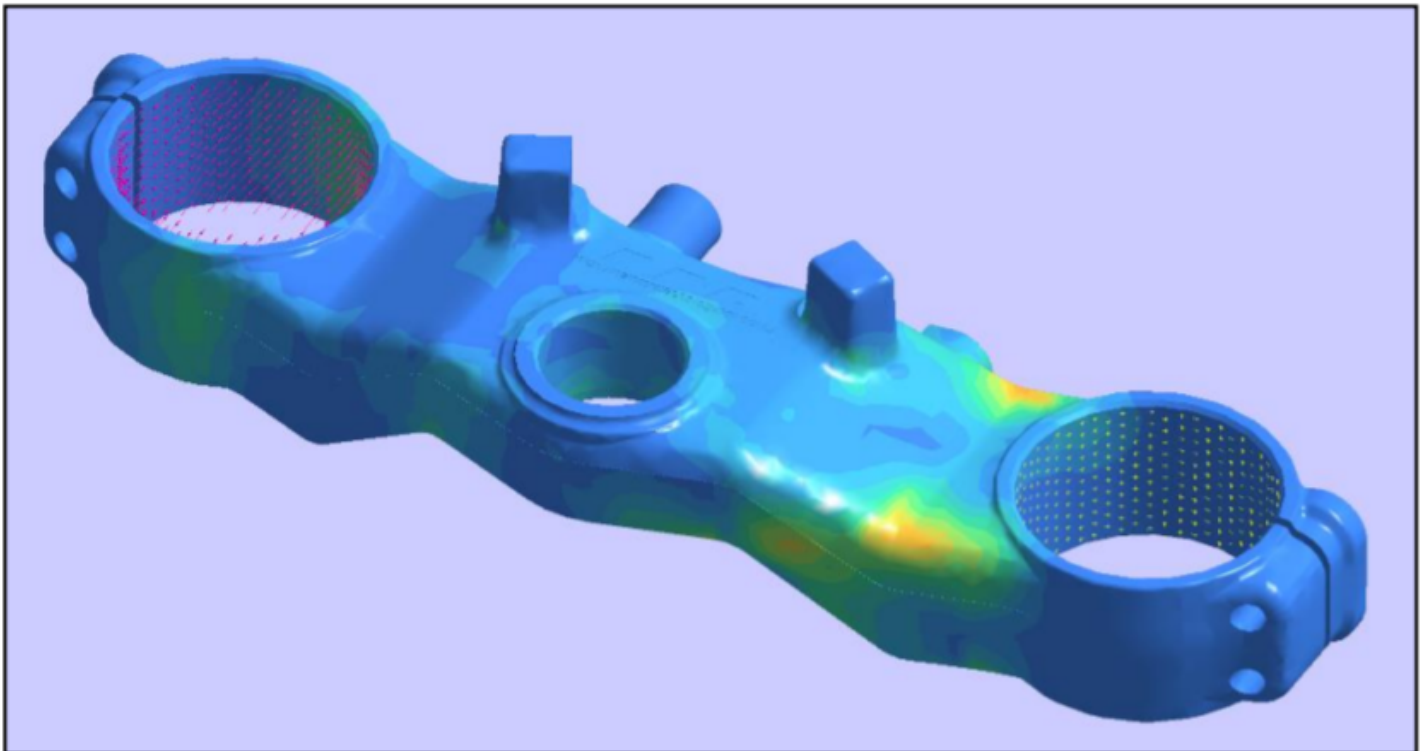

Direct simulation of large assemblies. Large assemblies with parts of varying size and shape can be directly analyzed in SimSolid. Here is an access platform consisting of 153 separate parts. Some parts are solid (ladder rungs), thin and hollow (tubular frame), complex (floor grate), or small (bolts, nuts, and washers). All geometric details, including threads in the nuts and bolts, are retained.

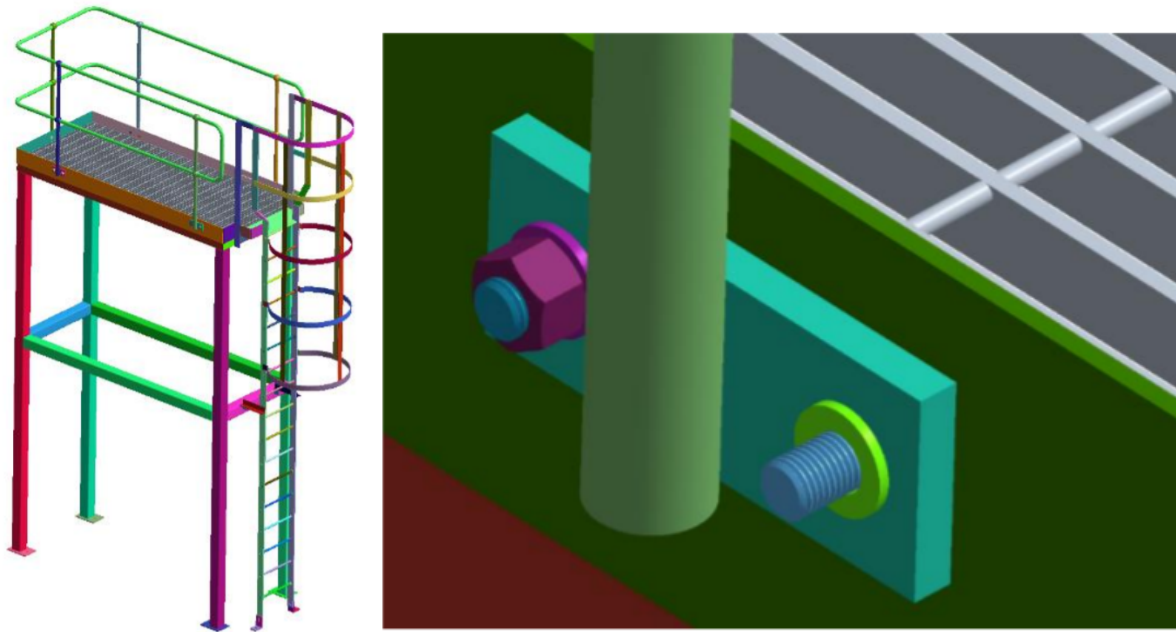

The model was imported directly from CAD without modification, and all connections were automatically determined. No meshing was required. The base was fixed and a simple side load applied. Total solution time (import, setup, and solution) was less than nine minutes using a desktop PC. A solution of this type would not be practical with traditional FEA.

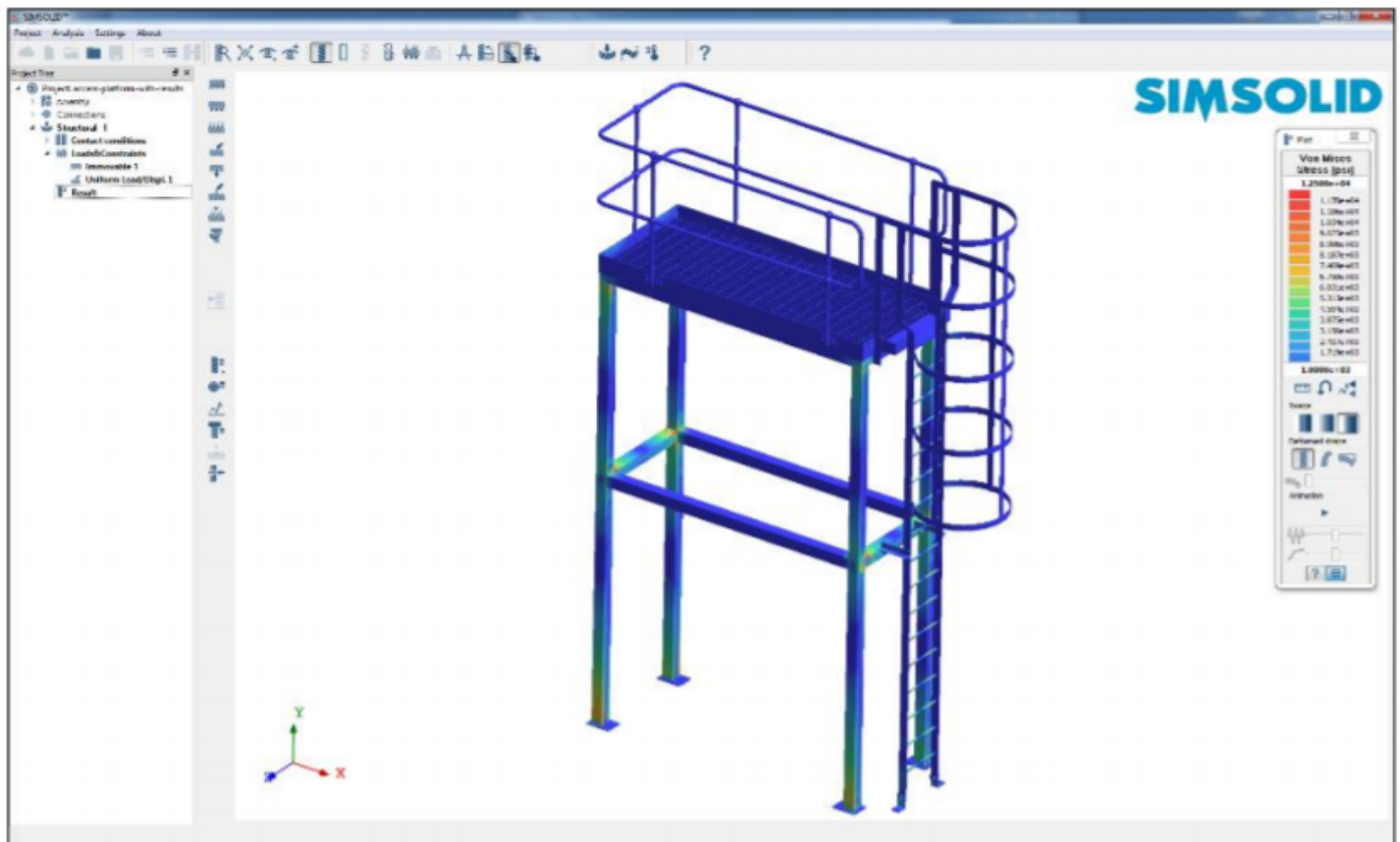

SimSolid Technology

The SimSolid technology approximates the solution domain using complicated polynomial and non-polynomial functions. It is an alternative to conventional FEA, where the approximations are built from primitive interpolation polynomials confined to finite elements of generic shapes like brick, tetrahedral, and wedge. Classes of applicable functions are significantly extended to accommodate solution-specific functions that approximate and meet certain solution features, such as incompressibility conditions, equilibrium equations, and asymptotic analyses around special geometric features. The accommodation of smart basis functions was made possible due to breakthrough extensions to the mathematical theory of external approximations, which decouples the basis functions from the underlying geometric shapes. The final functions are built on the fly from generic sets during the solution sequence. Generic sets are always complete, and their approximation properties are preserved in all transformations. This property of the basis functions enables the development of adaptivity strategies that can refine the generic sets in local regions as required to increase solution accuracy. In SimSolid, an extension of the fundamental concepts of numerical methods consists of the redefinition of the basic ideas of degrees of freedom (DOF). SimSolid does not use the pointwise DOF inherent in traditional FEA. The SimSolid DOF are functionals with geometric support in form of volumes, areas, line clouds, and point clouds. This provides the ability to handle geometric imperfections as well as assembly contact imperfections, like gaps, penetrations, and ragged contact areas.

Sources of Modeling Error in Traditional FEA

The implementation of analysis in the design process means that analysis results are used to make design decisions. It is, therefore, important that analysis tools provide results with predictable accuracy. Analysis results validation is a complex problem because all numerical methods are approximate, and there can be many sources of errors including the major ones: modeling errors and approximation errors. Modeling errors occur when the CAD geometry model is being modified to make it suitable for traditional FEA meshing. The modification can include many steps, such as assembly simplification, part defeaturing, surface idealization, and geometry-face cleanup. Successful meshing is a prerequisite for obtaining any results in FEA. Even if only global displacements are of interest, the geometry still has to be meshed to the smallest detail. Furthermore, meshing has to use the correct element type, show the correct element shape (no degeneration or bad aspect ratio), and have enough elements to model the expected stress pattern. These quality requirements are difficult to satisfy for complex parts. Adaptive remeshing to satisfy numerical convergence is possible but not practical in many situations and is not commonly performed in design analysis. For assemblies, the situation gets even worse because meshes in contact areas of parts must be either compatible or good enough to provide meaningful results. The latter is practically impossible in case of multiscale assemblies, when large parts are connected through small parts, such as bolts, nuts, rivets, and pins.

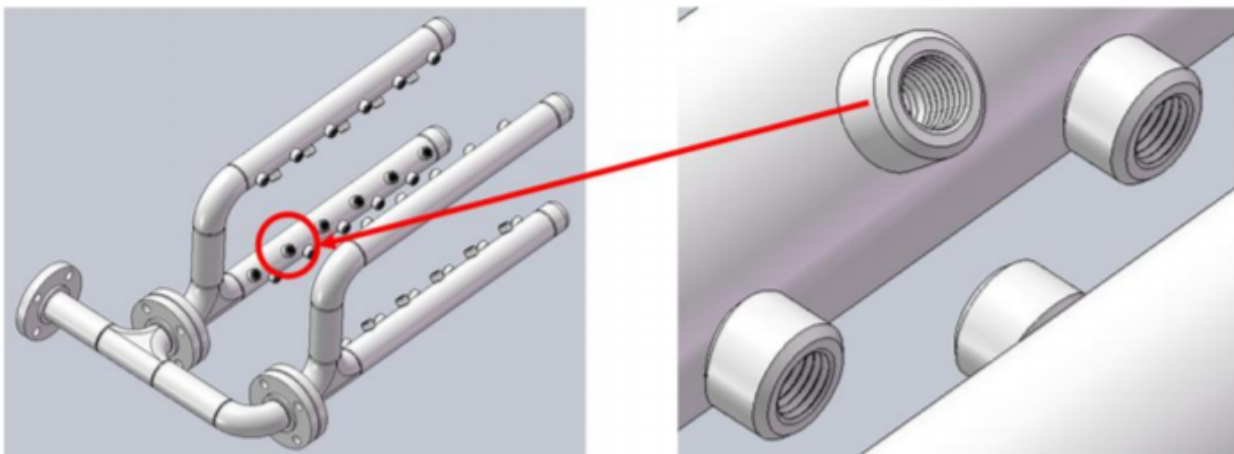

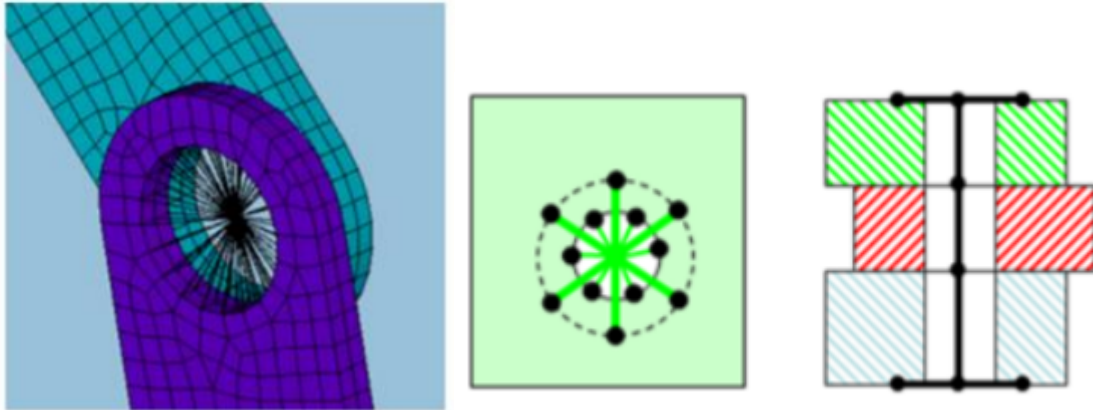

Assembly idealization is also dependent on the solution method. Here is an example of small parts that can be simply removed in static analysis but that need to be replaced by mass points or artificial bodies with six inertia moments in dynamic analysis in order not to change mass distribution in the structure. Other sources of error in traditional FEA include special element consideration for connections. Bolts and welds are problematic in that both special elements and special mesh patterns are required to model them adequately. To the left are examples of connection idealizations of a bolt replaced by beam and spider rods.

The final stumbling block is obtaining the solution. Even if model has been successfully meshed, finding the solution is still not assured. Having meshed complex geometry, the model is often found to be too large to be solved within a reasonable time or it contains poorly shaped elements that cause instabilities in the numeric of traditional FEA solver methods. Using the traditional FEA workflow to manage these potential error sources is complex. Training—and retraining—can be expensive and time-consuming. Occasional (infrequent) use of simulation is especially problematic. Errors introduced by the misapplication of a user interface workflow are far too common.

Sources of Modeling Error in Traditional FEA

SimSolid is new but it has been extensively tested by both Altair and outside companies in a variety of industries. We have produced a validation manual, available at www.altairhyperworks.com, that includes tests run as part of our standard quality-assurance process. One example from the validation manual—plate with a hole under extensional load—is included here.

Reference 372.7 MPa
SIMSOLID 369.2 MPa
Difference 0.9%

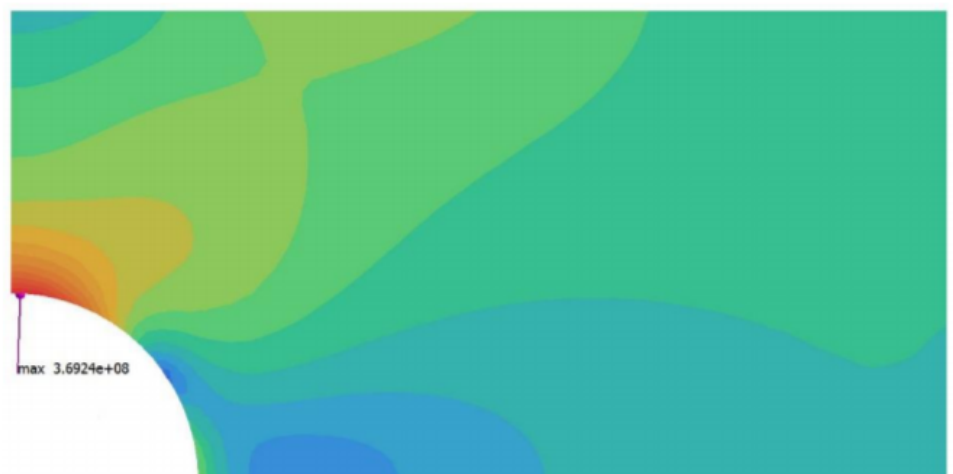

Conclusion

For simulation to truly drive the design process, it needs to work in step with each geometric concept and concept modification. The complexity of traditional FEA eliminates its use in all but the most trivial of design conditions. Simulation working directly on design geometry provides a path to quick, meaningful answers that can guide designers and engineers to more optimal design scenarios. Only SimSolid can provide this, by not only eliminating time-consuming and expertise-extensive geometry-simplification techniques, such as defeaturing and mid-surfacing, but also eliminating the mesh altogether. The result is a simulation tool that is both:

- fast enough, with respect to both model and solving time, to be used every day, and
- simple enough to be used occasionally without the need for extensive training and monitoring.

Try SimSolid for yourself. We think you will agree that it is how design simulation should be done. For more information and to conduct a trial simulation of our product, please visit our website at www.altair.com/simsolid.