

# e-mobility

technology international

VOL 9 | SUMMER 2021

## InMold Electronics for Automotive Applications

PAGE 40

The EV sector  
is on a very  
rapid growth  
curve, inspiring  
creativity and  
next generation  
innovations

PAGE: 10

Stronger global  
collaboration is essential  
for our Zero-carbon  
future

PAGE 86

THE VEHICLE AS  
A MOBILE DATA  
CENTER

PAGE 46

ENABLING KEY  
ELEMENTS FOR  
THE FUTURE OF  
E-MOBILITY

PAGE 30

PUTTING ELECTRIC  
VEHICLES TO THE  
TEST

PAGE 86





# Driving Model-Based Design to Accelerate Automotive Electrical Service

Gerhard Angst

Automotive electronics is experiencing a renaissance as car makers exploit complex technology to differentiate their products. This will only escalate as driverless vehicles become commonplace.

While the semiconductor designs are performed using state-of-the-art software tools and accurate system models, the automotive systems in which they reside are often described using traditional, static schematics. This leads to issues across the automotive value chain, from development, through manufacturing, to the all important service centers.

Model Based Design (MBD) techniques are starting to permeate the industry, enabling increased system complexity to be encapsulated and controlled throughout the development process. A “digital twin” virtualized system model allows for a high degree of dynamic analysis to be performed on the design before implementation, such that the full complexity of the system can be thoroughly tested and evaluated on its virtual twin. This has transformed development.

This notion of modeling holds significant potential as it extends beyond the confines of the development process to manufacturing and after-sales service. The dynamic capability of a system model can solve many of the issues confronting the over-worked service technician struggling to solve elusive issues in a modern automotive electronic system.

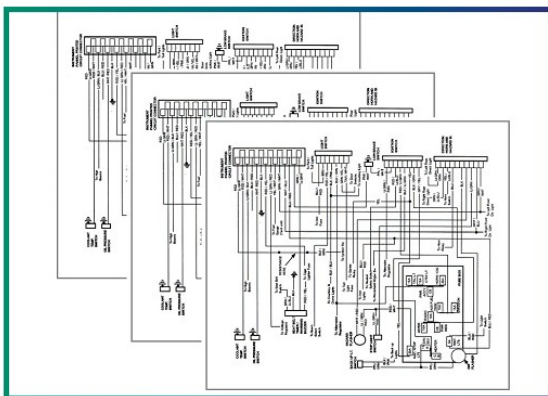

Traditional: Schematic-based

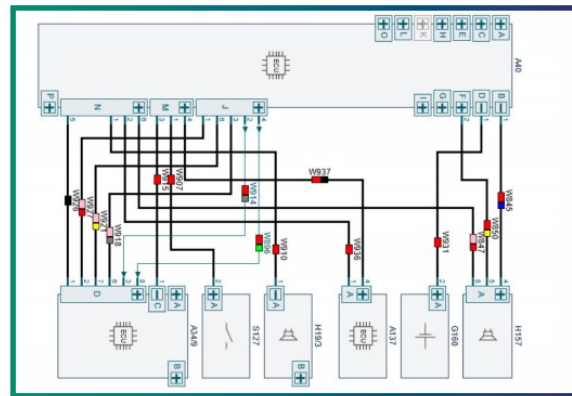

EEvission: Model-based

Online visualization tools read these electrical models and render them in a customized fashion for dynamic electrical system navigation, inspection, and debug. As we will see, this has a dramatic effect on service center and manufacturing productivity, bringing the power of the digital twin to bear on a traditionally paper-driven exercise.

**How do these tools work?** The model of an automotive electrical system is contained in a database, which may be derived automatically from various sources including the development ECAD system, Excel spreadsheets, or purpose-built converters for various programming environments. Specific details from the database, which may be stored on the end-user's computer or in the cloud, is read by the visualization tool. The technician is then able to specify an instant rendering display of the exact information required to target a specific problem, using searches, component names, signal paths, etc.

On an old car where the electrical system might consist of a few components that are obviously interconnected, such a scheme may not be necessary. However, the average modern automobile appears more like an array of computers on wheels. According to Chris Isidore of CNN Business, the average car of the 2020s contains between 50 to 150 semiconductor devices, 100 Electronic Control Units (ECUs), and miles of wiring. 30% of the cost of a modern car is its electronics. A fault in such a system requires a diagnosis methodology that fits this level of complexity.

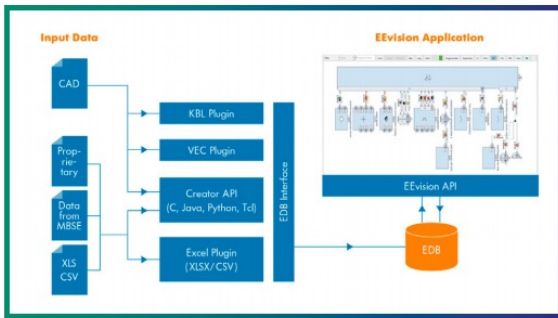

Let's say there is an issue with the gear shift indicator in a car, and the technician wants to understand the wiring harness between the gear position switch and the display, through harnesses, relays, connectors, and other controllers that might be in the wiring path. Traditionally, the paper or computer-based wiring schematics would be pulled up, and the technician would have to search through multiple static pages of detail, following complicated wiring tangles through page after page, trying to not accidentally skip to an incorrect signal. Of course, merely ensuring the right schematic is in use, is up to date, and is appropriate for the correct variation of the car, is troublesome

Using a model-based, dynamic, online visualization solution, the technician pulls up his or her trusty tablet and dials in the VIN number of the car and the name of the gear control (or any other vehicle function). The tool accesses the up-to-date database for the specific variation of the car, picks out the gear position switch (S139) and shows just the path to the instrument panel (A10), including the connectors and other components in that path, in a simple to read format. The technician can now check each one and find the fault quickly.

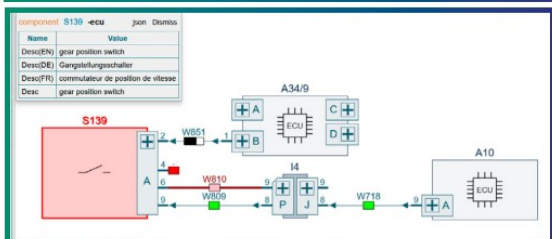

What if the technician does not know the name or part number of the dashboard ECU? Not a problem. The tool makes use of a Google search-like capability where the technician can just type in "dash" and that is enough for the tool to list out any component that contains those characters such as "dashboard", allowing the quick selection and analysis of the part.

e-mobility Technology International | www.e-motec.net

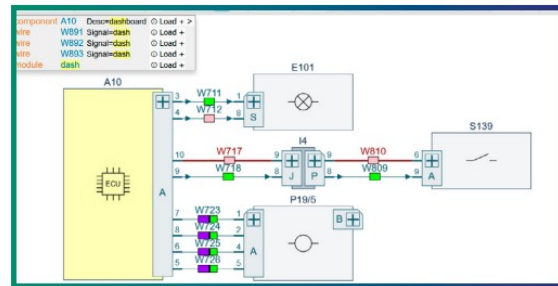

Because the visualization is specific to a scenario, it is possible to draw a clean, easy to understand, color graphic that contains all the correct information in a single place. Each component can be selected and part information, a photograph of the part, part descriptions and any other detail can be easily displayed. Full system views of an entire system may also be displayed to allow the operator to dive into detail from a known high-level view.

For development and manufacturing, the visualization tool can provide full documentation on the fly, a Bill of Materials (BoM), and other key information. The connectivity of the system can be checked, and the entire solution signed off using the digital model. Multiple models can be automatically compared with each other for updates or corrections that may not be valid.

Some business sectors, such as the semiconductor industry, have pioneered the use of advanced software tools to handle extreme complexity. Electronic graphics pioneer, Concept Engineering, has applied its advanced visualization technology used in other industries to the automotive sector, in the form of EEvision™, the first model-based dynamic visualization solution.

EEvision is already in use across the automotive industry, as well as in other sectors such as aerospace, industrial and transport applications. It has been employed across development and manufacturing teams, as well as in service centers where its use has significantly accelerated maintenance turnaround times to the benefit of vehicle providers and their end customers.

EEvision has also been employed in applications that simply cannot afford errors. It is in use by NASA/Jet Propulsion Laboratory (JPL) for Assembly, Test and Launch Operations on MARS 2020 Perseverance ROVER, the latest Mars mission, as well as other future missions. It may also be found on the racetrack, leveraged by one of the top Formula 1 teams where reliability and speed go hand in hand.

The Digital Twin and Model-Based Design has become a critical aspect of modern automobile development. EEvision allows these techniques to transform the efficiency and quality of the all-important after-sales servicing.

**Gerhard Angst, CEO Concept Engineering**