

Euro-Pro Embraces Simulation-Driven Design with Altair HyperWorks®

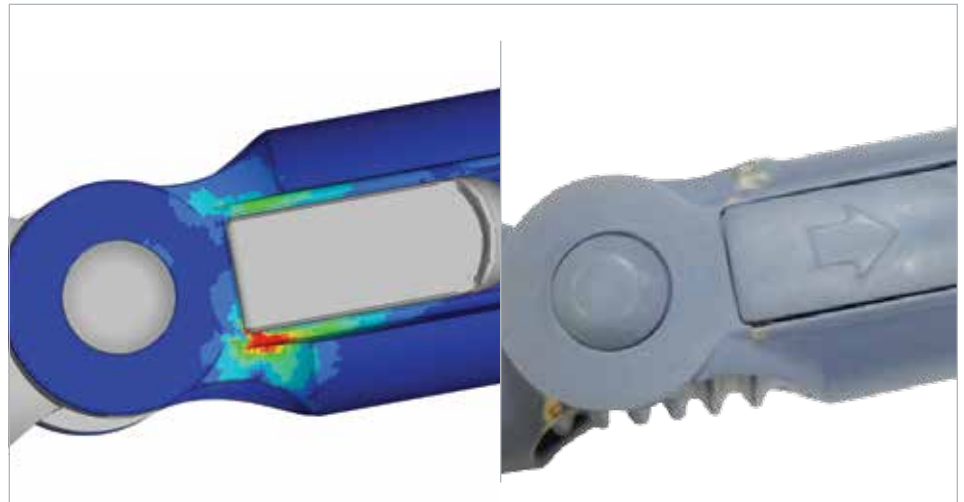

Key Highlights

Industry

Consumer Goods

Challenge

Introduce simulation driven philosophy as substantial part of development

Altair Solution

Altair solvers (OptiStruct, RADIOSS and AcuSolve) accessible via HPC cloud infrastructure

Benefits

- Reduce number of physical tests and gain deeper understanding of the product behavior
- Make product testing more scientific through simulation
- Improve product performance and durability

Customer Profile

Euro-Pro is a dynamic consumer products manufacturer that Inc. Magazine has named one of the fastest growing private companies in the United States for three consecutive years. Its revenues tripled between 1997 and 2013 from less than \$300m to over \$900m. The company boasts several household names in its product arsenal, including Ninja blenders and Shark vacuums.

While the bulk of Euro-Pro's engineering team is located in China, research and development (R&D) is in the United States. Product computer-aided design (CAD files originate with the team in China, and members of the R&D team use computer-aided engineering (CAE) tools and technologies to perform analysis. This includes all

repetitions of tests required in preparation for product launch. Historically, R&D was primarily responsible for physical testing to fix product failures.

A number of years ago, the company made a conscious decision to implement simulation to improve product performance and reduce the number of physical tests. Reliable drop testing, strength and durability analysis, and fluid analysis are all requirements of the Euro-Pro product development process. Flow analysis is performed to increase the suction power of vacuums and the mixing effectiveness of blenders. Assessments of optimal nozzle shape and the imposition of different parameters to test and improve particle pick-up effectiveness are also utilized.

Euro-Pro Success Story



"The Altair business model was the clincher for me in terms of overall value and ease of implementation. One vendor means lower integration costs, and Altair's focus on timely, effective, and responsive customer support is critical."

Pu Zhou
Senior Mechanical Engineer
Euro-Pro LLC.

The Challenge:

CAE is somewhat new to the company and concentrated in R&D, where it is being used to enhance the physical testing and product quality assurance process. The overall product development process is dependent upon physical prototype testing, which until recently included little to no simulation.

Increasing the use of simulation would give the team the ability to conduct more analysis of scenarios that may be impossible to test physically, for example internal structural failures. In some situations, it takes too long to prototype and is too costly to conduct as many tests as the analyst might prefer. In addition, with physical testing, the analyst does not always understand what

really happened during the drop or impact. Causality can be more precisely determined with the use of simulation.

From a pure analysis perspective, identification of the root cause of fracture or failure would help the R&D team give better guidance to the engineering and product design leads in China. The R&D team is interested in becoming more of a strategic consultant to Euro-Pro product development. Team members would like to test materials prior to their introduction on future generation products, in hopes of positively influencing the overall product portfolio direction with respect to market appeal, quality, reliability, and durability, including materials development and selection.

The Solution:

In terms of structural analysis, drop simulation has become Euro-Pro's priority. Cleanup and meshing remain the toughest tasks HyperMesh® is used to correct the geometry. Some aspects of its cleanup functionality are not available in competitive products. The team estimates time savings of around 50% on meshing alone. Also, finite element analysis (FEA) provides more insight into impacts and cross-sections than was feasible with physical testing. An advantage of simulation is that an analyst may go "inside" the product to see how components interact. This level of scrutiny was not possible previously. Physical testing continues in parallel, but is now informed by CAE results.

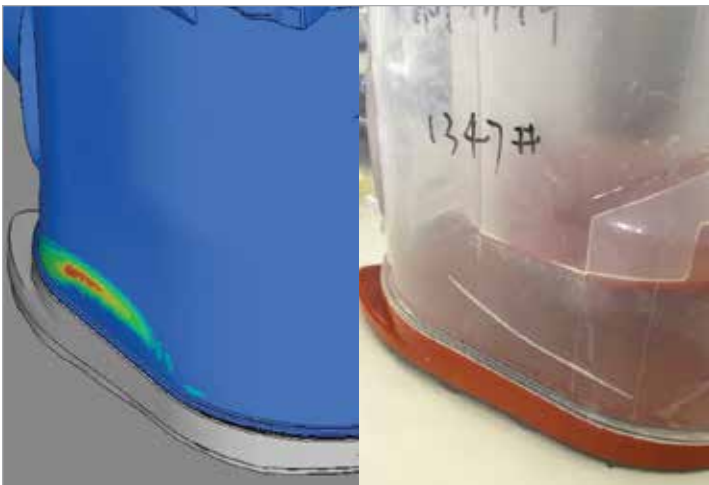

Simulating drop tests with RADIOSS shows the root cause of failure and helps with finding corrective actions

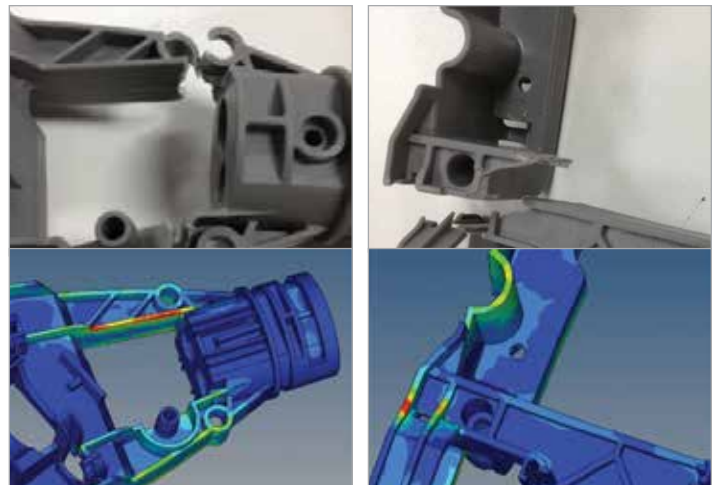

Static analysis with OptiStruct unveils weak spots on plastic parts, before they are produced

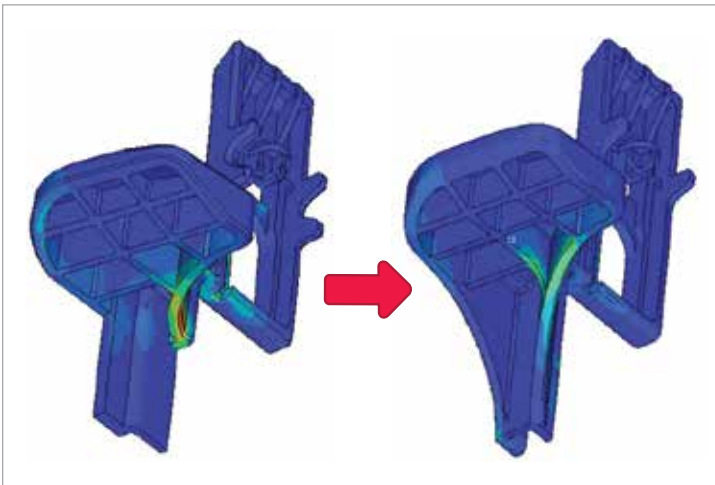

Comparison between variations helps quantifying improvements and meeting product requirements

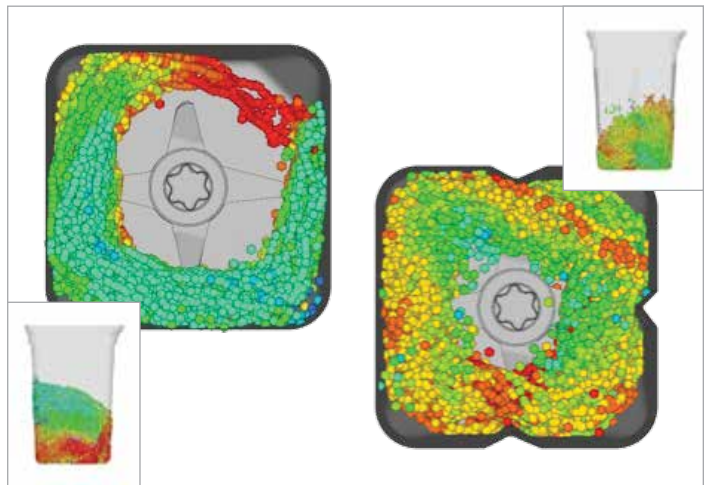

SPH analysis with RADIOSS helps exploring how different designs affect the flow inside a blender

RADIOSS® is a very accurate structural analysis solver, cost-efficient, and can cover most of the bases for the CAE team. AcuSolve®, a computational fluid dynamics (CFD) solver also contained within HyperWorks®, offers great accuracy for thermal and flow analysis in comparison to physical testing. Correlations to physical tests have been proven and are helping to build credibility within the company. With AcuSolve, analysts do not have to have a very structured mesh, which saves a lot of time in the CAE model preparation phase. Ease of use and speed are major reasons for increasing adoption of AcuSolve at the company.

"I had already been exposed to HyperMesh prior to my job at EuroPro, but I was not aware of Altair's additional solver capability," observed Mr. Zhou. "The Altair business model was the clincher for me in terms of overall value and ease of implementation. One vendor means lower integration costs, and Altair's focus on timely, effective, and responsive customer support is critical."

Euro-Pro wanted its vacuum cleaners to be sturdy enough to withstand accidental drops or impacts occurring during normal usage without mechanical failures or housing cracks. Using HyperMesh and RADIOSS, team members developed a finite element representation of vacuum cleaner sections and then subjected them to various drop test and impact scenarios. CAE techniques helped analysts better understand the root cause of potential problems, enabling them to rectify design issues without having to constantly build and test models at the point of failure reporting. Fixing problems

quickly and efficiently, early in the design process, reduces design iterations and costs associated with product failures. Demonstrated success using CAE to improve product quality, reliability, and durability convinced Euro-Pro engineers to increase analysis cycles early in the design process, including virtual testing to see if a new design could withstand typical usage scenarios. Engineers have now extended this CAE methodology to the Ninja line of blenders.

Euro-Pro is accessing all of these solutions via HyperWorks On-Demand™, a high-performance computing (HPC) solution for design innovation in the cloud based on Altair's patented usage-based license model. This approach alleviates the cost burden of significant computing hardware, as well as the overhead of people hours spent maintaining it. An added benefit of a scalable HPC infrastructure is that, while a compute-intensive job is running, other jobs may be processed in parallel.

The Results:

Until recently, there was no CAE being performed at Euro-Pro. R&D lead Pu Zhou, is building the entire CAE infrastructure from the ground up. This involves not only establishing internal CAE competencies in various focus areas, like structures, dynamics, thermal, and fluids, but also the socialization of the overall value proposition and product development methodology across the company. In short, Mr. Zhou is establishing a CAE center of excellence in order to enable the adoption of a simulation-driven design philosophy by Euro-Pro.

Now, the Euro-Pro R&D team can perform more virtual tests of different designs to see how they perform. Team members have also been able to change the cost component of products by simulating performance with different materials using FEA. CAE results are also providing the rationale for maintaining quality materials in the final product design. Manufacturing problems have been averted or prevented through the use of simulation.

While Euro-Pro still maintains a physical testing standard, by informing the testing process using CAE, product outcomes have been improved. Once a component goes into production, tools and dies have been manufactured, so failure is expensive. The simulation process makes the physical testing process more scientific to reduce rework and redesign, reducing manufacturing costs, shortening time-to-market, and improving product quality and appeal.

In future if all goes well, Mr. Zhou would like to give some analysis capabilities to the engineering team. His view is that simulation-driven design is the wave of the future, and his partnership with Altair has been an enabler. "I think HyperWorks is helping us design better products."

Visit the HyperWorks library of
Success Stories
at www.altairhyperworks.com

About Altair

Altair's vision is to radically change the way organizations design products and make decisions. We take a collaborative approach to solving diverse and challenging problems through the strategic application of technology and engineering expertise. Developing and applying simulation technology to synthesize and optimize product development processes for improved business performance is our specialty.

From computer-aided engineering to high performance computing, from industrial design to cloud analytics, for the past 30 years Altair has been leading the charge to advance the frontiers of knowledge, delivering innovation to more than 5,000 corporate clients representing the automotive, aerospace, government and defense industries and a growing client presence in the electronics, architecture engineering and construction, and energy markets.

About HyperWorks®

Performance Simulation Technology

HyperWorks is an enterprise simulation solution for rapid design exploration and decision-making. As one of the most comprehensive, open-architecture CAE solutions in the industry, HyperWorks includes best-in-class modeling, analysis, visualization and data management solutions for linear, nonlinear, structural optimization, fluid-structure interaction, and multi-body dynamics applications.

www.altairhyperworks.com



Altair Engineering, Inc., World Headquarters: 1820 E. Big Beaver Rd., Troy, MI 48083-2031 USA
Phone: +1.248.614.2400 • Fax: +1.248.614.2411 • www.altair.com • info@altair.com

Listed below are HyperWorks® applications. Copyright© 2014 Altair Engineering Inc. All Rights Reserved for: HyperMesh®, HyperCrash®, OptiStruct®, RADIOSS®, HyperView®, HyperView Player®, HyperStudy®, HyperGraph®, MotionView®, MotionSolve®, HyperForm®, HyperXtrude®, Process Manager™, Templex™, Data Manager™, MediaView™, BatchMesher™, TextView™, HyperMath®, Manufacturing Solutions™, HyperWeld®, HyperMold®, solidThinking®, solidThinking Evolve™, solidThinking Inspire®, Durability Director™, Suspension Director™, AcuSolve®, AcuConsole®, HyperWorks On-Demand™, HyperWorks Enterprise™, PBS Works™, PBS Professional®, GridWorks™, PBS GridWorks®, PBS™, Portable Batch System®, PBS Analytics™, PBS Desktop™, e-BioChem™, e-Compute™ and e-Render™. All other marks are the property of their respective owners.