

## Haier Redesigns Air Conditioners and Packaging with Altair HyperWorks to Eliminate Drop Damage



### Key Highlights

#### Industry

Electronics

#### Challenge

Introduce simulation driven philosophy as substantial part of development

#### Altair Solution

Simulated Drop Testing with HyperWorks

#### Benefits

- Drop Damage was eliminated
- Efficient use of packaging material
- Reduce costly physical testing

### Customer Profile

Haier Group is one of the world’s largest manufacturers of home appliances and consumer electronics. The company is the leader of its industry in China, where it is headquartered.

Haier ships its products all across the globe and in more than 100 countries, so well-designed product packaging is crucial to the company’s ability to deliver products without damage to even the farthest destinations.

### The Challenge: A lower-cost way to prevent drop damage

While the company is known for its quality products, the air conditioners it manufactured were being damaged during transportation, leading to higher costs and delays in final product delivery.

Haier tried to improve the structure of its air conditioners as well as its packaging to make them more resistant to drop damage by

conducting physical drop tests. These tests, however, significantly increased the products’ research-and-development costs, and they consumed an extraordinary amount of time.

In physical tests, engineers could not easily observe the damage process because the collision between the product and the ground was an instantaneous event. They could view the outcome but not the strains and shape changes during the fractions of seconds in which they happened.

“The deformation time in the drop test is typically less than 50 milliseconds,” said Haier Engineer Yundong Chen, “and the model is packed in a non-transparent box, which makes it difficult to observe the internal deformation process.”

As a result, Haier considered using excessive packaging materials, but the overall design strength of the package was insufficient.

# Haier Group Success Story

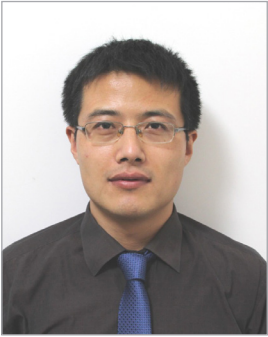

**“Simulation with HyperWorks brought great efficiencies and savings to the redesign process. It helped reduce the huge amount of work involved in physical tests of the product and its packaging, making redesign more efficient and eliminating the costs of physical testing.”**

**Yundong Chen,**  
Senior CAE Engineer,  
Haier Group

## The Solution: Simulated drop testing with HyperWorks

Haier engineers turned to HyperWorks tools from Altair to create a virtual simulation of a drop test that would provide extensive data on the stresses and strains involved. Virtual drop tests using HyperMesh for pre-processing and the RADIOSS solver were developed for two different types of air conditioners to gain better insights.

For the first product tested, Haier engineers initially conducted numerous physical tests to collect data on the performance of the materials used in the packaging, such as honeycomb panels and EPS blocks. Then it simulated material tests with virtual models to calibrate the data.

They tested honeycomb paper through elastic deformation, buckling, plastic collapse and brittle rupture of the product under

axial compression. After obtaining the strain-stress curve from the physical model, the team simulated the honeycomb paper and reproduced the axial compression virtually. The virtual compression test curve showed very good conformity with the experimental physical test curve.

The engineers employed HyperMesh in the pre-processing of both the air conditioner structure and its packaging. Then, to carry out the simulation, they set an initial velocity for a drop and added gravity as a factor.

They used the HyperWorks suite’s RADIOSS explicit solver to perform the drop-test analysis, and HyperView and HyperGraph to generate reports on the results. HyperWorks enabled Haier to carry out the entire simulation process within one CAE environment.

For the second type of air conditioner, Haier engineers again prepared separate models for the air conditioner and the packaging and then employed RADIOSS in simulating a 0.8 meter drop on a corner of the package, with a beginning speed of 3.96 mm/ms. Engineers subsequently conducted follow-up simulations for other conditions.

“By using RADIOSS for a fast and accurate solution,” said Chen, “we could study all the parameters, such as stress, strain and displacement, rather than merely looking at the air conditioner damage after real drop tests and imaging of the drop process.”

## The Results: Drop damage was eliminated

For the first air conditioner, the initial drop simulations showed a substantial deformation when the product was dropped on one corner.

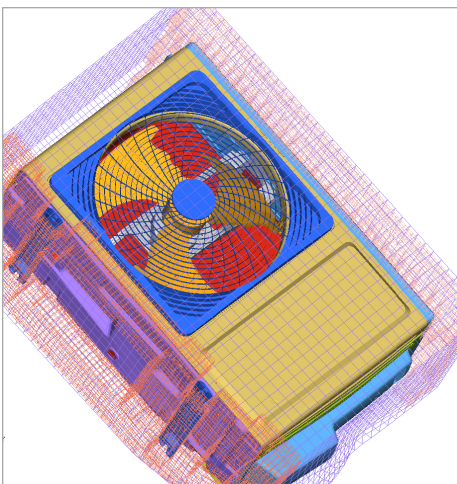

Drop test of first AC unit with RADIOSS

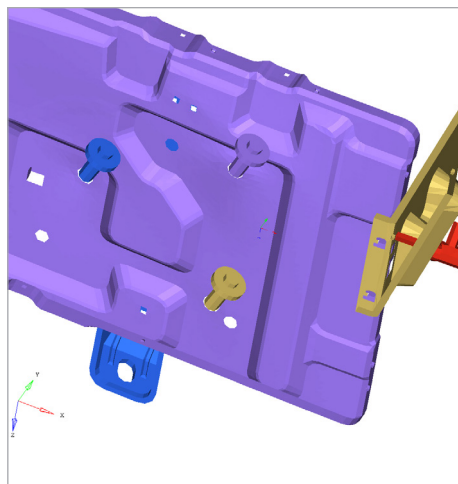

Simulation unveils weak metal chassis

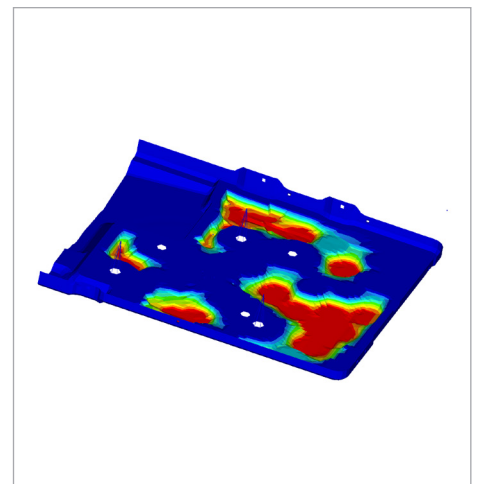

Improved bead design with OptiStruct topography optimization

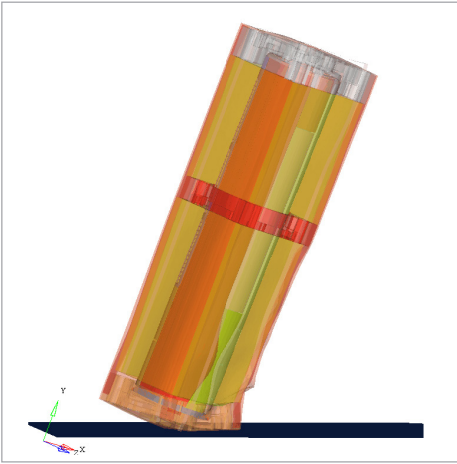

Second AC unit drop test

Engineers could see from the simulation that the strength of the corners of the machine itself was not sufficient to withstand such a drop, with the local plastic strain reaching 40.2 percent. Additionally, engineers determined that the thickness of the packaging pad was too small to serve as a buffer during a drop, allowing the product's chassis to recess when it struck the ground.

Haier redesigned the structural base of the air conditioner as well as the packaging and then conducted the same drop-test simulation with a refined model.

"This test revealed that the structural strength of the machine corner had been strengthened in the refined model," Chen said, "with the local plastic strain dropping to 0 percent and no permanent deformation of the product."

For the second air conditioner, finite element analysis found that the base of the appliance sustained a strain value of 71.6 percent and readily showed that the problem resulted from the initial thickness and shape of the packaging design.

Engineers used HyperMesh to quickly optimize the packaging, remodeling thickness and shape, therefore sharply reducing the strain value to just 6.1 percent.

"This meant the new packaging design presented close to no risk of damage during a fall," Chen observed. "We could meet all the design requirements while greatly shortening the development time. A subsequent bench test also validated the CAE findings."

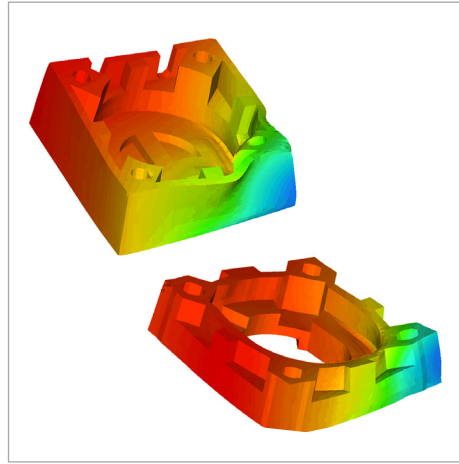

Improved EPS block design performs better over the original design despite 28 % in weight savings.

### Optimization to improve product design

Once Haier engineers had resolved drop-test issues, they took additional steps to optimize the design of the air conditioner chassis itself with Altair's optimization tool OptiStruct.

"We understood the value of looking into a solution to evaluate product performance during the development stage," said Chen, "to shorten development time and save cost. By using Altair OptiStruct's optimization techniques in the air conditioner's structure, we felt we could increase product reliability."

Previous methods of evaluating the mechanical structure's stress and strain values through applied material mechanics and elasticity calculations were complicated because of complex geometry and load. Mathematical solutions often were incomplete or yielded results that were very different from the actual situation.

"While checking the strength of the mechanical structure for reliability, the selected safety factors are often too big," Chen explained, "resulting in the size and weight of the structure design being too large. Moreover, since the calculation and analysis are rough, some weaknesses may occur."

### The Results: A stronger structure with no change in composition

Haier performed a drop analysis of the chassis model using RADIOSS and found that the design of the chassis area that

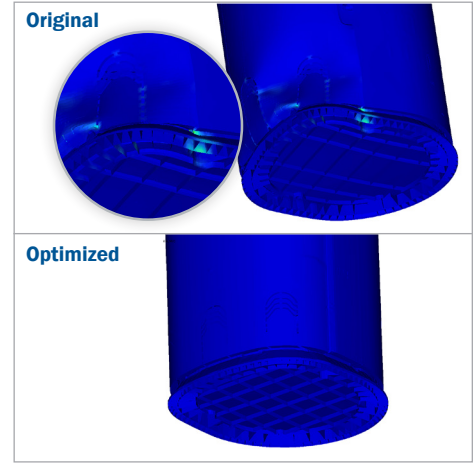

Comparison of deformations on the original and optimized design of the AC unit foot.

supports the compressor was overly simple and weak. Corners were drastically deformed in the simulations and compressor bolts appeared to loosen.

Through topology optimization with OptiStruct, engineers were able to improve the structural strength of the air conditioner chassis by 40 percent without changing its composition and to test the optimized structure afterward.

Chen said that Haier engineers identified a number of benefits in using HyperWorks tools: The reasons for parts failure could be found quickly and accurately. With HyperWorks post-processing software, engineers could see every moment of the drop testing process and extract such numerical data as stress, strain and displacement to analyze the product's behavior.

Haier was able to use packaging and structural material more reasonably after the simulation. Once the reason for the failure was found, engineers could redesign the product in the appropriate way, reducing trial-and-error costs.

Simulation with HyperWorks brought great efficiencies and savings to the redesign process. It helped reduce the huge amount of work involved in physical tests of the product and its packaging, making redesign more efficient and eliminating the costs of physical testing.

Simulation was highly accurate, thanks to the capabilities of the RADIOSS solver. With the multi-CPU technology and quality scaling ability of RADIOSS, the drop-test analysis produced high computational efficiency.

Visit the HyperWorks library of  
**Success Stories**  
at [www.altairhyperworks.com](http://www.altairhyperworks.com)

## About Altair

Altair's vision is to radically change the way organizations design products and make decisions. We take a collaborative approach to solving diverse and challenging problems through the strategic application of technology and engineering expertise. Developing and applying simulation technology to synthesize and optimize product development processes for improved business performance is our specialty.

From computer-aided engineering to high performance computing, from industrial design to cloud analytics, for the past 30 years Altair has been leading the charge to advance the frontiers of knowledge, delivering innovation to more than 5,000 corporate clients representing the automotive, aerospace, government and defense industries and a growing client presence in the electronics, architecture engineering and construction, and energy markets.

---

## About HyperWorks®

Performance Simulation Technology

HyperWorks is an enterprise simulation solution for rapid design exploration and decision-making. As one of the most comprehensive, open-architecture CAE solutions in the industry, HyperWorks includes best-in-class modeling, analysis, visualization and data management solutions for linear, nonlinear, structural optimization, fluid-structure interaction, and multi-body dynamics applications.

[www.altairhyperworks.com](http://www.altairhyperworks.com)



**Altair Engineering, Inc., World Headquarters:** 1820 E. Big Beaver Rd., Troy, MI 48083-2031 USA  
Phone: +1.248.614.2400 • Fax: +1.248.614.2411 • [www.altair.com](http://www.altair.com) • [info@altair.com](mailto:info@altair.com)

Listed below are HyperWorks® applications. Copyright© 2014 Altair Engineering Inc. All Rights Reserved for: HyperMesh®, HyperCrash®, OptiStruct®, RADIOSS®, HyperView®, HyperView Player®, HyperStudy®, HyperGraph®, MotionView®, MotionSolve®, HyperForm®, HyperXtrude®, Process Manager™, Templex™, Data Manager™, MediaView™, BatchMesher™, TextView™, HyperMath®, Manufacturing Solutions™, HyperWeld®, HyperMold®, solidThinking®, solidThinking Evolve™, solidThinking Inspire®, Durability Director™, Suspension Director™, AcuSolve®, AcuConsole®, HyperWorks On-Demand™, HyperWorks Enterprise™, PBS Works™, PBS Professional®, GridWorks™, PBS GridWorks™, PBS™, Portable Batch System™, PBS Analytics™, PBS Desktop™, e-BioChem™, e-Compute™ and e-Render™. All other marks are the property of their respective owners.