

Iowa State University

Cyclone Racing



Images courtesy of Iowa State University

CYCLONE RACING, Iowa State University's Formula SAE team consists of 40+ active members who design, build, test, and race a formula style race car each year to compete with approximately 80 teams representing seven different countries at the Formula Lincoln event and approximately 30 different teams at the Formula North event. Cyclone racing is currently ranked 4th in the United States and 14th in the world out of 550 teams. Most aspects of being a professional racing team are evaluated and judged, and the team operates largely from private sponsorship with support from Iowa State University. Teams must demonstrate a top-performing racing machine on the track, and also demonstrate their working knowledge in engineering and marketing through a series of presentation events.

When designing their latest vehicle, CR22, one of the team's goals was to reduce the weight of the vehicle's rear aerodynamic wing. Nate Lenz, Cyclone Racing's Technical Director at the time noted, "With last year's car, the internal wing structure was very heavy, to the point that we would see some very excessive roll, and a few times, even though the car was super fast, we would find ourselves up on two wheels. Keeping that in mind, a huge goal with this year's car was to reduce the weight of the entire wing package, while also ensuring that it was very strong and stiff."

Nate first learned about solidThinking Inspire from a flyer he saw posted on his campus. He noted, "It immediately caught my attention and I thought it was fascinating, but other priorities came up and I did not have a chance to try it at that time." When the project to redesign the bracket mount for the rear wing package came up, Nate immediately thought of Inspire. "Knowing that the mount had to be extremely light, while also being as stiff as possible, it seemed like a perfect project to try Inspire on. After struggling to complete the project with some other tools, I downloaded solidThinking Inspire."



INDUSTRY

Automotive/Formula Racing

CHALLENGE

Decrease vehicle weight and performance by designing a lightweight, yet extremely stiff modified swan neck wing mount for Formula SAE vehicle.

SOLUTION

Utilization of simulation using solidThinking Inspire to generate a new design concept for the mount in the initial phases of the concept design process.

RESULTS

- Reduction in bracket weight of 4lbs (67% decrease in aerodynamic mounting weight)
- Lowered center of gravity
- Verification of the new design through analysis results
- Manufacturing of new parts conducted with aluminum waterjet cutting
- Successful racing and competition season using redesigned mount
- Exceeded in design review due to knowledge of loading and analysis results

SOLIDTHINKING INSPIRE IN THE DESIGN PROCESS

The first step to using Inspire was to learn how to use the tool successfully. Nate mentioned, "Inspire was very intuitive to learn, it honestly only took about 5 hours of working through the tutorial models for me to become comfortable with using the tool." Once confident enough with the tool and its capabilities, the team created an initial design space for the brackets in an external CAD tool. "This particular beam was unique in that it had to stretch over a long distance, be high off the ground, and put under a bending load. The nice thing with it was that we were only constrained by the mounting locations so we were able to work through a few different design space options, as well as loading scenarios prior to ending up on the final design." After running through a number of different iterations in Inspire, the team was able to select a final optimized design for the bracket which it then used Inspire, as well as third-party analysis and verification tools in order to simulate and analyze the performance of the part.

After the design was verified, the team moved into the manufacturing process where the new brackets were manufactured using waterjet cutting which was not only quick, but also very cost effective. Nate mentioned, "I really liked being able to set the different manufacturing and symmetry constraints in Inspire, this allowed us to design the part specifically for the manufacturing process we wanted to use."

RESULTS

The new swan neck wing mounts were a huge success, not only did Inspire allow the team to design the parts for the specific manufacturing process they wanted to use (waterjet), but it also enabled them to significantly reduce the weight of the entire wing package from approximately 7lbs to 4lbs. Nate noted, "The weight reduction in the mounts was significant, we even went from a hollow wing last year, to a foam-filled wing this year, which increased its weight, so the reduction in weight for the mounts was imperative. This ultimately helped reduce the weight of the entire car and helped us perform better in competition. The mounts were not only very light, but they were also very stiff and survived all of the rigors that our competitions put on them. My teammates regularly come up to me now and say 'hey Nate, can you solidThinking this part for us?'"

WHAT'S NEXT?

Today, Nate is on the Senior Design Team of Cyclone racing where he and the team are currently working on some new and exciting projects. He mentioned, "We plan to continue to use Inspire. Right now we are completely looking to redesign the car's differential. This will be integrated into the car with a number of new mounts, as we will be going from a floating differential and floating engine, to now having them mounted in-between each other. We are working on taking the new loads from the chain tension and applying these in Inspire to generate and design all of the new mounts which will be water jetted or machined." Nate also mentioned that a number of other teammates are working on learning Inspire so Cyclone racing can use and reap the benefits of using the tool into the future.

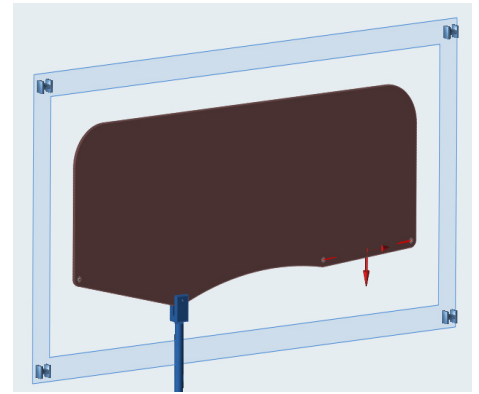

Mount Design Space and Loads Setup in Inspire

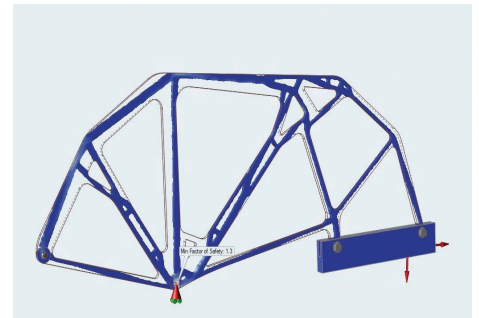

New Optimized Mount Design and Analysis in Inspire



Full wing Structure including Optimized Swan neck Mounts

ABOUT IOWA STATE UNIVERSITY

Iowa State University SAE International is a student organization of five teams: Baja, Clean Snowmobile Challenge, Aero, Formula and Supermileage. Iowa State University SAE International's mission is to expand upon the ISU classroom education through participation, leadership, outreach, design, and fabrication in the Baja, Clean Snowmobile, Formula, and Supermileage SAE Collegiate Design Series competitions. These international sanctioned competitions allow colleges from around the world to compete every year.

Iowa State University SAE 2025 Black Engineering
Ames, IA 50011
stuorgs.engineering.iastate.edu/sae/

