

NASA-JPL ADOPTS EEVISION

ELECTRONIC SYSTEM VISUALIZATION HELPS ACCELERATE MARS AND JUPITER MISSIONS

About the Customer

[Jet Propulsion Laboratory \(JPL\)](#), a federally funded research and development center managed for NASA by Caltech, is implementing different programs in planetary exploration, Earth science, space-based astronomy, and technology development.

Their Challenge

JPL's space mission "[Europa Clipper](#)" is an interplanetary mission planned for launch in October 2024 that will conduct reconnaissance of Jupiter's moon Europa and investigate whether the icy moon could harbor conditions suitable for life. JPL's [Mars Sample Return](#) mission will use the Perseverance Rover to collect material from Mars to determine whether life ever existed on the Red Planet. Capturing requirements and implementing designs for these programs and their complex electrical systems is highly iterative and cyclical. JPL needed to implement a model-based, requirements-driven process to improve the development process for these endeavors and future ones.

Our Solution

Engineers and technicians often use static schematic diagrams covering complex and extensive electrical systems. The ability to quickly render scenario-specific schematics based on search criteria of a connected digital twin model represents a leap forward in manufacturing and development efficiency.



We are proud to support NASA/JPL to get their missions and projects into space more quickly and more reliably. With many different team members working on flight projects, JPL was eager to use our cloud-based visualization functionality to provide different team members with instantly available, accurate, and up-to-date system schematics.

Gerhard Angst, VP EDA
and Industrial Solutions, Altair

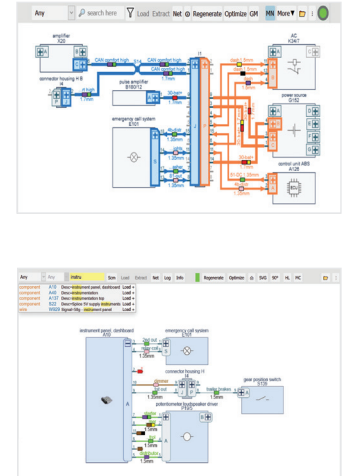
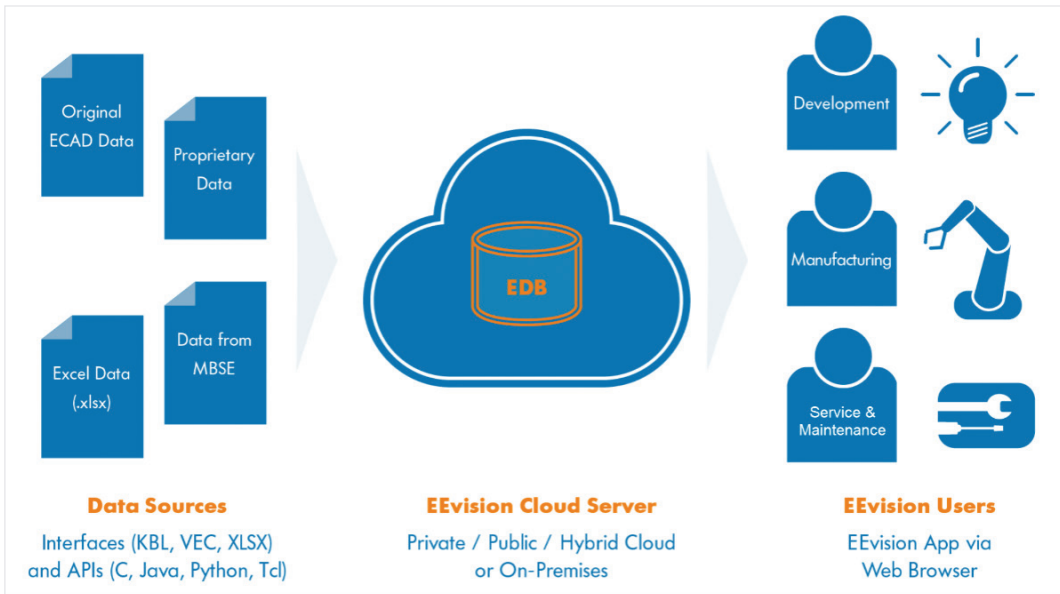

On May 24, 2019, Concept Engineering (now part of Altair), announced JPL's plans to use the [Altair® EEvision™](#) system visualization software to accelerate development, manufacturing, and testing for JPL's missions to Mars and Europa. Replacing the manually drawn and maintained schematic diagrams with auto-generated, on-the-fly schematics accessed from a digital twin model allows easy access to any system function or incrementation system exploration. EEvision speeds up development, manufacturing, and testing times while reducing error potential by providing auto-generated correct-by-construct pictures. And when needed, documentation can be quickly and automatically generated.

Results

EEvision's unique ability to automatically generate and visualize system diagrams and harness cable diagrams supports JPL's new model-based development flow. Replacing manually drawn and maintained schematic diagrams with easy-access, auto-generated diagrams from a digital twin model reduces errors and saves time. All these innovations lead to better, more efficient, more effective processes and spacecrafts.

Thanks in part to Altair's leading technology, JPL and NASA can conduct their visionary missions to the Solar System's most intriguing planetary bodies and moons, and can help humans understand the past, present, and future potential of our stellar neighbors.

To learn more, please visit altair.com/eevision

LEFT: Digital twin model data is accessible in the cloud at all stages of development.
TOP RIGHT: Automatically render schematic diagrams to identify regions of influence*.
BOTTOM RIGHT: Smart search and show to easily explore and debug complex systems*

*example circuit images not provided by JPL.