

# BOOSTING MINE CHUTE DESIGN

## IMPROVE CHUTE DESIGN AND REDUCE COSTS WITH ALTAIR EDEM™

### About the Customer

Wood provides engineering, procurement, and construction management (EPCM) services to IAMGOLD, operator of the Côté Gold Project, supported by its joint venture partner Sumitomo Metal Mining Co. Ltd., on the construction of the Côté Gold Project. The Côté Gold Project site is located in the Sudbury district of northeast Ontario. This new open pit gold mine and its accompanying processing plant is expected to have a throughput of 36,000 tons per day and operate 365 days a year around the clock.



“Altair EDEM” gave us a better understanding of the flow of the material, and more importantly operating issues that could be designed out before the build. Since then, the Côté project has integrated the use of this technology in many areas. Altair EDEM further de-risks the project by engineering and puts our best foot forward for success in being part of the transformation of IAMGOLD.

JianFeng Wang, IAMGOLD

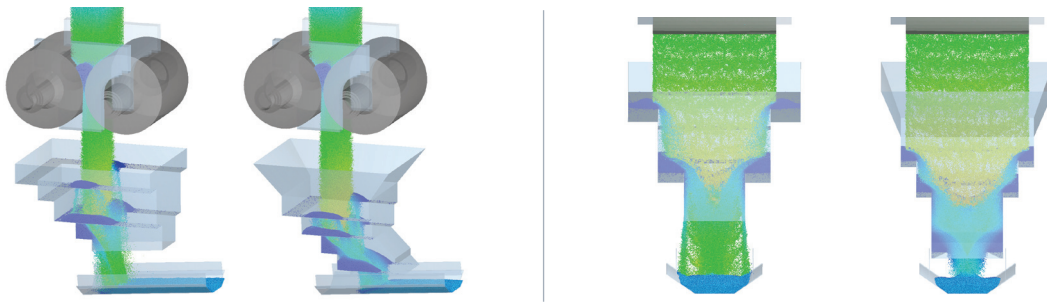

### Their Challenge

Wood is responsible for assessing material handling transfer chutes for crushed ore. The large number of transfer chutes must be optimized to enable the transfer of bulk material from one conveyor belt to another, and to adequately direct the flow of material. Some of the most common issues with material transfer designs include plugging, segregation, and abrasion wear. In an effort to reduce operating maintenance costs, Wood employed the use of Altair EDEM, a discrete element modeling (DEM) solution, to visualize the flow of material and analyze forces and moments acting on different parts of the transfer chute.

### Our Solution

Altair collaborated with Wood to ensure the correct parameters were employed when simulating cohesionless, free-flowing bulk materials. The experimentally measured angle of repose was used in order to calibrate the simulations input parameters.

The transfer chute presented here directs the flow of material from the high-pressure grinding roller (HPGR) to a conveyor belt to be screened. The HPGR reduces the particle size by compressing the material between two counter rotating rollers, exceeding the compressive strength of the ore, causing it to fracture. This simulation analyzed specifically the flow of material within the transfer chute. To reduce the complexity of the contact model, the particle size distribution at the outlet of the HPGR was assumed to be the inlet feeding the rollers.

The initial visualization of the DEM results showed an opportunity to reduce the platework within the transfer chute since the majority of the material flowed directly underneath the opening of the rollers (see Figure 1). As a result, angled plates were implemented. Furthermore, centering plates were added at the bottom of the transfer chute, improving the material distribution on the belt, reducing the velocity of the material and ensuring that the belt was not side loaded (see Figure 2).

### Results

Following its use of EDEM, Wood reduced the weight of this transfer chute by approximately 10%, adding \$20,000 in NPV to the project.

The DEM result showed a potentially costly operating expenditure since the material discharge at the bottom of the transfer chute was not impacting the centre of the conveyor belt, resulting in poor loading conditions (refer to Figure 2).

Not only did the visualization of the bulk material flow reduce the material needed to fabricate this transfer chute, it shed light on possible bottleneck and maintenance issues during operation by improving the loading conditions on the conveyor belt.

To learn more, please visit [altair.com/edem](https://altair.com/edem)

**LEFT:** Figure 1 - Velocity contour of original transfer chute design (left) versus modified transfer chute design (right) **RIGHT:** Figure 2 - Velocity contour of conveyor belt loading conditions in original transfer chute design (left) versus modified chute design (right)